

Air Accidents Investigation Branch

Department for Transport

**Report on the accident to
Boeing 777-222, registration N786UA
at London Heathrow Airport
on 26 February 2007**

This investigation was carried out in accordance with
The Civil Aviation (Investigation of Air Accidents and Incidents) Regulations 1996

The sole objective of the investigation of an accident or incident under these Regulations shall be the prevention of accidents and incidents. It shall not be the purpose of such an investigation to apportion blame or liability.

© *Crown Copyright 2009*

Published with the permission of the Department for Transport (Air Accidents Investigation Branch).

This report contains facts which have been determined up to the time of publication. This information is published to inform the aviation industry and the public of the general circumstances of accidents and serious incidents.

Extracts can be published without specific permission providing that the source is duly acknowledged.

Published 16 April 2009

Printed in the United Kingdom for the Air Accidents Investigation Branch

**RECENT FORMAL AIRCRAFT ACCIDENT AND INCIDENT REPORTS
ISSUED BY THE AIR ACCIDENTS INVESTIGATION BRANCH**

**THE FOLLOWING REPORTS ARE AVAILABLE ON THE INTERNET AT
<http://www.aaib.gov.uk>**

7/2007	Airbus A310-304, F-OJHI on approach to Birmingham International Airport on 23 February 2006.	December 2007
1/2008	Bombardier CL600-2B16 Challenger 604, VP-BJM 8 nm west of Midhurst VOR, West Sussex on 11 November 2005.	January 2008
2/2008	Airbus A319-131, G-EUOB during the climb after departure from London Heathrow Airport on 22 October 2005.	January 2008
3/2008	British Aerospace Jetstream 3202, G-BUVC at Wick Aerodrome, Caithness, Scotland on 3 October 2006.	February 2008
4/2008	Airbus A320-214, G-BXKD at Runway 09, Bristol Airport on 15 November 2006.	February 2008
5/2008	Boeing 737-300, OO-TND at Nottingham East Midlands Airport on 15 June 2006.	April 2008
6/2008	Hawker Siddeley HS 748 Series 2A, G-BVOV at Guernsey Airport, Channel Islands on 8 March 2006.	August 2008
7/2008	Aerospatiale SA365N, G-BLUN near the North Morecambe gas platform, Morecambe Bay on 27 December 2006.	October 2008
1/2009	Boeing 737-81Q, G-XLAC Avions de Transport Regional ATR-72-202, G-BWDA, and Embraer EMB-145EU, G-EMBO at Runway 27, Bristol International Airport on 29 December 2006 and 3 January 2007.	January 2009

**Department for Transport
Air Accidents Investigation Branch
Farnborough House
Berkshire Copse Road
Aldershot
Hampshire GU11 2HH**

March 2009

*The Right Honourable Geoff Hoon
Secretary of State for Transport*

Dear Secretary of State

I have the honour to submit the report by Mr K Conradi, an Inspector of Air Accidents, on the circumstances of the accident to Boeing 777-222, registration N786UA at London Heathrow Airport on 26 February 2007.

Yours sincerely

David King
Chief Inspector of Air Accidents

Contents

Synopsis.....	1
1 Factual Information	3
1.1 History of the flight.....	3
1.2 Injuries to persons	4
1.3 Damage to the aircraft.....	4
1.4 Other damage	6
1.5 Personnel Information.....	6
1.5.1 Commander.....	6
1.5.2 Operating First Officer.....	7
1.5.3 Relief First Officer	7
1.6 Aircraft Information.....	8
1.6.1 General information.....	8
1.6.2 Aircraft maintenance history	8
1.6.3 Insulation blanket specification and maintenance	9
1.6.4 Smoke detection and cooling system in the MEC	10
1.6.5 Boeing 777 electrical power distribution and control system.....	10
1.6.5.1 Contactor control	12
1.6.5.2 Power transfers	12
1.6.5.3 No-break power transfer (NBPT)	12
1.6.6 Boeing 777 electrical power system protection.....	14
1.6.7 Contactor description (model ELM 827-1)	16
1.6.8 Electrical system principles of heat and resistance.....	21
1.6.9 General principles of arcing and arcing containment.....	22
1.6.10 Number of contactor cycles per flight.....	23
1.6.11 Differences between ELMS 1 and ELMS 2 power panels	23
1.7 Meteorological information	24
1.8 Aids to navigation.....	24
1.9 Communications	24
1.10 Aerodrome Information	24
1.11 Flight recorders	24
1.11.1 General.....	24
1.11.2 Flight recorder operation	25
1.11.3 CVR installation	25
1.11.4 FDR electrical system parameters	25
1.11.5 FDR warning parameters	26

1.11.6	Recorded fault messages from GCUs and BPCU.....	26
1.11.7	Summary of relevant data recorded during the event.....	28
1.11.8	Data prior to the event	31
1.12	Aircraft examination.....	31
1.12.1	General aircraft examination	31
1.12.2	Structural damage examination	33
1.12.3	Wiring damage examination.....	34
1.12.4	Insulation blanket examination.....	35
1.12.5	P200 power panel examination.....	38
1.12.6	Examination of Generator Control Units.....	38
1.12.7	Examination of the failed contactors	40
1.12.7.1	RGCB contactor examination.....	40
1.12.7.2	RBTB contactor examination	42
1.13	Medical and pathological information.....	44
1.14	Fire.....	44
1.14.1	Response by the airport fire service to the accident.....	44
1.14.2	Fire damage.....	45
1.15	Survival aspects.....	45
1.16	Tests and research	45
1.16.1	Overview.....	45
1.16.2	Tests of the insulation blanket material	45
1.16.3	Other Boeing 777 contactor and power panel failure incidents....	48
1.16.3.1	Failures involving ELMS 2 power panels	48
1.16.3.2	Failures involving ELMS 1 power panels	52
1.16.4	Examination of failed contactor from A6-EBF incident in August 2006.....	52
1.16.5	Examination of a sample of high cycle/ high time contactors from the fleet.....	53
1.16.5.1	Examination of LBTB, LGCB and APB from N786UA	59
1.16.5.2	Examination by ERA of a high time/ high cycle contactor.....	59
1.16.6	Endurance test of an instrumented contactor.....	60
1.16.7	Fault testing of a contactor.....	63
1.16.8	Examination of previous contactor manufacturing quality issues...	64
1.16.9	Power transfer ground test results.....	65
1.16.10	Contacting insulating material properties.....	65
1.17	Organisational and management information.....	67

1.18	Additional information.....	67
1.18.1	Flight crew checklists	67
1.18.2	Consequences of the N786UA failure condition occurring in flight.....	68
1.18.3	Probability of the N786UA failure condition occurring in flight...	68
1.18.4	Safety action taken.....	69
1.18.4.1	Safety action taken by the aircraft manufacturer	69
1.18.4.2	Containment tray modification	71
1.18.4.3	Implementation of a flight deck smoke warning.....	74
1.18.4.4	Safety action taken by the contactor manufacturer	74
2	Analysis.....	79
2.1	Electrical failure event sequence.....	79
2.2	Electrical system protection	81
2.3	Possible causes of contactor failure	82
2.3.1	Heat-related possible causes of contactor failure	83
2.3.2	Non-heat-related possible causes of contactor failure	85
2.3.3	Summary of possible causes of contactor failure	89
2.4	Probable cause of previous power panel failures.....	91
2.5	Fire and smoke in the Main Equipment Centre	92
2.5.1	Effectiveness of the fire retardant insulation blankets	92
2.5.2	Flight crew awareness of smoke in the MEC	92
2.5.3	Containing and preventing fire in the MEC.....	93
2.6	Action to prevent future recurrence	95
3	Conclusions	97
3.1	Findings.....	97
3.2	Causal factors.....	99
4	Safety Recommendations.....	100

Appendices

Appendix A	Boeing 777 Electrical Power System Schematic
Appendix B	NBPT timeline diagram
Appendix C	Analysis of NVM fault messages
Appendix D	Timeline of relevant events from CVR, FDR and NVM data
Appendix E	Results from insulation blanket tests
Appendix F	Tyco report on endurance contactor test

GLOSSARY OF ABBREVIATIONS USED IN THIS REPORT

A	Ampere	N2	Engine high pressure compressor speed
AAIB	Air Accidents Investigation Branch	PEPC	Primary External Power Contactor
AC	Alternating Current	PPS	Polyphenylene Sulphide
AD	Airworthiness Directive	PTFE	PolyTetraFluoroEthylene
AFS	Airfield Fire Service	QAR	Quick Access Recorder
AGCU	APU Generator Control Unit	QNH	pressure setting to indicate elevation above mean sea level
AMP	Ampere	RAT	Ram Air Turbine
APB	Auxillary Power Breaker	RBTB	Right Bus Tie Breaker
APU	Auxiliary Power Unit	RGCB	Right Generator Circuit Breaker
ATC	Air Traffic Control	RGCU	Right Generator Control Unit
BPCU	Bus Power Control Unit	rpm	revolutions per minute
BTB	Bus Tie Breaker	RT	Radio Telephony
BU	Backup	SEm	Scanning Electron Microscope
°C	Degrees Celsius	SEPC	Secondary External Power Contactor
CT	Current Transformer	SPS	Sustained Parallel Source
CVR	Cockpit Data Recorder	UTC	Co-ordinated Universal Time (the contemporary equivalent of GMT)
DC	Direct Current	UV	Under-voltage
ECN	Engineering Change Number	V	Volts
EDX	Energy Dispersive X-ray	VDC	Volts Direct Current
EE	Electrical Equipment	VHF	very high frequency
EICAS	Engine Indication and Crew Alerting System	V/mil	Volts per thousandth inch
ELMS	Electrical Load Management System	WES	Warning Electric System
EQA	Equipment Quality Analysis		
FAA	Federal Aviation Administration (USA)		
FAR	Federal Aviation Requirement (USA)		
FDR	Flight Data Recorders		
FTP	Functional Test Procedure		
GCR	Generator Control Relay		
GCU	Generator Control Unit		
GSR	Ground Series Relay		
HMV	Heavy Maintenance Visit		
hrs	hours (clock time as in 12:00 hrs)		
Hz	Hertz		
IDG	Integrated Drive Generator		
KHz	kilohertz		
kva	Kilovolt-amperes		
lb	pound(s)		
LBTB	Left Bus Tie Breaker		
LGCB	Left Generator Circuit Breaker		
LGCU	Left Generator Control Unit		
m	metres		
MEC	Main Equipment Centre		
mm	millimetre(s)		
MOM	Multi operator Message		
ms	milliseconds		
mV	millivolts		
NBPT	No-break Power Transfer		
NPRM	Notice for Proposed Rule Making		
NVM	Non-Volatile Memory		
OEM	Original Equipment Manufacturer		

Air Accidents Investigation Branch

Aircraft Accident Report No: 2/2009 (EW/C2007/02/07)

Operator: United Airlines Incorporated
Aircraft Type and Model: Boeing 777-222
Registration: N786UA
Location: London (Heathrow) Airport, UK
Latitude: N 051° 29'
Longitude: W 000° 28'
Date and Time: 26 February 2007 at 1000 hrs
All times in this report are UTC

Synopsis

The aircraft operator's duty manager at Heathrow notified the Air Accidents Investigation Branch (AAIB) of the accident at 1140 hrs on 26 February 2007 and the investigation commenced the next day. The AAIB investigation team comprised:

Mr K Conradi	(Investigator-in-Charge)
Mr N Dann	(Operations)
Mr S Hawkins	(Engineering)
Mr R James	(Flight Recorders)

A preliminary report on the initial findings from the accident was published in AAIB Special Bulletin S2-2007 on 17 April 2007. This formal report contains the final findings and Safety Recommendations from the investigation.

The accident occurred during engine start after pushback from the stand. After the right generator came online an electrical failure occurred in the right main bus. The failure resulted in severe internal arcing and short circuits inside the two main power contactors of the right main bus. The heat generated during the failure resulted in the contactor casings becoming compromised, causing molten metal droplets to fall down onto the insulation blankets below. The insulation blankets ignited and a fire spread underneath a floor panel to the opposite electrical panel (P205), causing heat and fire damage to structure, cooling ducts and wiring. The flight crew responded to the bus failure and

a burning smell by shutting down the right engine and taxiing to a nearby stand. The Airfield Fire Service attended the aircraft when it arrived on stand and entered the Main Equipment Centre where they discovered significant smoke but no fire. The passengers were evacuated uneventfully via steps.

The investigation identified the following causal factors:

1. An internal failure of the Right Generator Circuit Breaker or Right Bus Tie Breaker contactor on the P200 power panel inside the Main Equipment Centre resulted in severe internal arcing and short-circuits which melted the contactor casings. The root cause of contactor failure could not be determined.
2. The open base of the P200 power panel allowed molten metal droplets from the failed contactors to drop down onto the insulation blankets and ignite them.
3. The aircraft's electrical protection system was not designed to detect and rapidly remove power from a contactor suffering from severe internal arcing and short-circuits.
4. The contactors had internal design features that probably contributed to the uncontained failures.

Five Safety Recommendations were made.

1 Factual Information

1.1 History of the flight

The aircraft was pushed back from the stand with the Auxiliary Power Unit (APU) running¹, the towbar was disconnected and both engines were started in quick succession. The flight crew, comprising a commander, operating first officer and a relief first officer (occupying the jump seat), reported that the engine starts appeared to be normal. At about the time when the engine integrated drive generators (IDGs) would normally come online, the flight crew saw the instrument displays flicker and heard a low-pitched, intermittent growling noise coming from the aft right side of the flight deck. A few seconds later, they received an Engine Indication and Crew Alerting System (EICAS) caution for ‘ELEC AC BUS R’, indicating that the Right Main AC Bus had failed. The right ‘GEN CTRL OFF’ light also illuminated on the overhead panel, which indicated that electrical power had been cut from the right IDG. Subsequently they observed that, on the ‘R BUS TIE’ switch, the ‘ISLN’ caption had illuminated, which indicated that the Right Bus Tie Breaker had been triggered to open.

The Flight Data Recorder (FDR) revealed that 40 seconds after both engines had stabilised at ground idle, the smoke detector inside the Main Equipment Centre (MEC)² detected smoke. Coincident with this, the Cockpit Voice Recorder (CVR) recorded the sound of cooling fans powering down and crew comments to the effect that the whole Right Main Bus had failed.

The flight crew selected the ‘ELEC AC BUS R’ Irregular Procedures checklist on the EICAS and completed the first action of selecting the right generator control switch to OFF and then to ON again. About two and a half minutes after the electrical failure they became aware of a faint electrical burning smell and shortly afterwards noticed the ‘EQUIP COOLING OVRD’ advisory message on the EICAS. At this point the commander ordered the first officer to shut down the right engine.

The ground handling crew observed smoke emanating from the MEC vent at the front of the aircraft and alerted the flight crew. Two minutes later ATC advised that smoke had been seen coming from the aircraft and that the fire service had been requested to attend as a precaution. The aircraft was taxied onto

1 Prior to APU start the aircraft was being powered by both its Primary External Power connector and its Secondary External Power connector.

2 The MEC is located beneath the flight deck and contains the majority of the aircraft’s electric and avionics equipment. The FDR parameter which indicates smoke in the MEC is called ‘EE Bay Smoke Warn’, although no such warning is displayed to the flight crew.

a nearby stand using the left engine. Once on stand the flight crew shut down the left engine and the APU, at which time light smoke appeared in the flight deck. ATC further advised that smoke had been seen coming from a forward vent. Approximately twelve and a half minutes after the electrical failure the batteries were switched off and the passengers and crew disembarked via steps placed at the aircraft.

Airfield Fire Service (AFS) personnel checked the aircraft’s MEC, which was filled with smoke, but did not detect any fire. They manually opened the forward cargo compartment and removed two cargo pallets to check for any additional signs of fire, but none were found. The smoke slowly cleared in the MEC to reveal obvious signs of fire damage.

1.2 Injuries to persons

<i>Injuries</i>	<i>Crew</i>	<i>Passengers</i>	<i>Others</i>
Fatal	0	0	0
Serious	0	0	0
Minor/None	20	185	

1.3 Damage to the aircraft

An inspection inside the MEC after the accident revealed extensive heat and fire damage to the P200 power panel which is located to the right of the nose gear wheel well (see Figure 1). The worst affected components of the power panel were the Right Generator Circuit Breaker (RGCB) and Right Bus Tie Breaker (RBTB) contactors, parts of which had melted and vaporised (see Figure 2). There was evidence that molten metal had dripped down onto the insulation blankets beneath the power panel. There was extensive fire damage to the fire-retardant insulation blankets located behind the power panel and beneath the panel under the floor, as shown in Figure 3. Nearby components including a floor panel, equipment cooling system ducting, other wire bundles and some structural frames and stringers in the vicinity were later determined to have suffered sufficient heat damage to require replacement. A more detailed description of the aircraft damage is included in section 1.12.

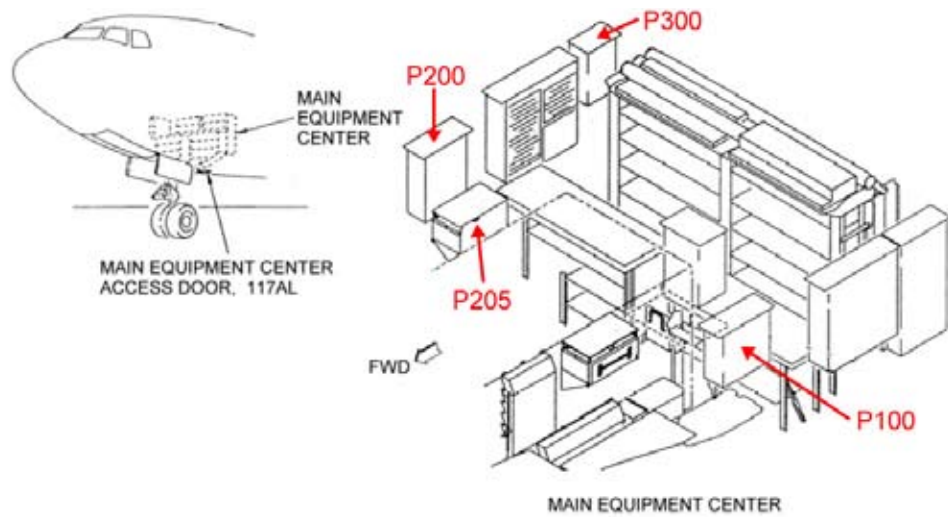

Figure 1

Location of P200 power panel and nearby panels in the MEC



Figure 2

Fire damage to P200 power panel (cover removed), showing burnt-out RGCB and RBTB contactors (viewed looking forward and to the right)



Figure 3

Burnt aircraft structure and insulation blankets located directly below P200 power panel (viewed looking down and aft; the floor panel has been removed)

1.4 Other damage

None.

1.5 Personnel Information

1.5.1 Commander

Age:	52 years
Licence:	Airline Transport Pilot's Licence
Aircraft Rating:	Boeing 777
Licence Proficiency Check:	Valid to 31 December 2007
Instrument Rating:	Valid to 31 December 2007
Operator's Line Check:	Valid to 30 September 2007
Medical Certificate:	Valid to 31 March 2007, with no limitations
Flying Experience:	Total all types 18,000 hours
	On Type: 3,300 hours
	Last 90 days: 212 hours
	Last 28 days: 65 hours
	Last 24 hours: 0 hours
Previous rest period:	27 hours

1.5.2 Operating First Officer

Age: 56 years
Licence: Airline Transport Pilot's Licence
Aircraft Rating: Boeing 777
Licence Proficiency Check: Valid to 31 December 2007
Instrument Rating: Valid to 31 December 2007
Operator's Line Check: N/A
Medical Certificate: Valid to 30 April 2007, must wear corrective lenses

Flying Experience: Total all types 21,000 hours
On Type: 7,415 hours
Last 90 days: 200 hours
Last 28 days: 65 hours
Last 24 hours: 0 hours

Previous rest period: 24 hours

1.5.3 Relief First Officer

Age: 47 years
Licence: Airline Transport Pilot's Licence
Aircraft Rating: Boeing 777
Licence Proficiency Check: Valid to 31 December 2007
Instrument Rating: Valid to 31 March 2007
Operator's Line Check: N/A
Medical Certificate: Valid to 30 June 2007, must wear corrective lenses

Flying Experience: Total all types 14,393 hours
On Type: 5,138 hours
Last 90 days: 147 hours
Last 28 days: 50 hours
Last 24 hours: 0 hours

Previous rest period: 24 hours

1.6 Aircraft Information

1.6.1 General information

Manufacturer:	The Boeing Commercial Airplane Group
Type:	Boeing 777-222
Aircraft serial no:	26938
Year of manufacture:	1997
Number and type of engines:	2 Pratt & Whitney PW4000 SER turbofan engines
Total airframe hours:	43,519 hours
Total airframe cycles:	6,622 cycles
Certificate of Registration:	Issued 4 April 1997 and valid
Certificate of Airworthiness:	Issued 3 April 1997 (non-expiring)

1.6.2 Aircraft maintenance history

The aircraft's last 'C' maintenance check was carried out on 29 December 2004 and its last 'Heavy Maintenance Visit' (HMV) check was carried out on 12 May 2000; this was also its first HMV. The aircraft did not have any outstanding defects relating to the electrical system at the time of the accident. An examination of Chapter 24 (electrical system) maintenance records dating back to 1 January 2005 did not reveal any faults or maintenance work that might be relevant to the cause of the contactor failures.

The insulation blankets in the MEC around the P200 power panel were last inspected during the aircraft's HMV check. The job cards for the HMV revealed that the insulation in this area was removed and restored, but not replaced. No discrepancies with the condition of the insulation blankets were noted.

The RBTB and RGCB contactors share the same part number (ELM827-1) and there is no maintenance requirement to replace either contactor after a fixed time or flight cycle period; they are 'on-condition' components. The serial numbers on the RBTB and RGCB contactors were unreadable as a result of the fire damage, but an inspection of the aircraft's maintenance records revealed that neither component had been replaced since the aircraft was manufactured in 1997. The records for the P200 power panel that was installed during aircraft manufacture revealed that the RGCB fitted was serial number CL-49080 and the RBTB fitted was serial number CL-49078. Both of these contactors were manufactured in February 1995. The accumulated flight hours and cycles for these contactors were therefore equal to the aircraft's total flight hours and cycles (ie 43,519 hours and 6,622 flight cycles).

1.6.3 Insulation blanket specification and maintenance

The insulation blankets fitted to the fuselage structure adjacent to the P200 power panel were determined to be the original equipment manufacturer (OEM) blankets, fitted in 1997. These blankets consisted of fibreglass batting (see Figure 21, page 37) covered with a polyethylene terephthalate film. The fibreglass batting contains fire-retardant compounds. These insulation blankets were required to pass the vertical Bunsen burner flammability test in accordance with FAR³ 25.853. This test specifies that a '3 inch by 12 inch' blanket sample be inserted into a Bunsen burner flame⁴ for 12 seconds and then removed. To pass the test, any flame on the sample must extinguish within 15 seconds after the Bunsen burner is removed; the burn length of the sample must not exceed 8 inches; and any burning drips from the sample must extinguish within 5 seconds. The aircraft manufacturer also subjected the insulation to a Cotton swab flame propagation test (BSS7357) – more details of which are contained in section 1.16.2. In 2008 the US FAA issued an Airworthiness Directive (2008-23-09) requiring the replacement of certain insulation blankets manufactured with some types of polyethylene teraphthalate film. The insulation blankets installed in N786UA were not among those whose replacement was required.

In 2005 the aircraft manufacturer introduced a new type of insulation blanket which used the same fibreglass batting but had a new covering film that was more resistant to radiant heat. This insulation was developed in order to pass a more stringent fire test involving a 2,000°F (1,093°C) propane flame whilst exposed to radiant heat. This type of insulation was not fitted to N786UA and there was no requirement for retrofit.

Contamination on insulation blankets can affect the blanket's fire retardant capabilities. The aircraft manufacturer published a Service Letter (777-SL-25-018) on 23 March 1998 which informed operators of:

'the potential fire hazard if combustible materials (contamination) such as overspray of corrosion inhibiting compound (CIC), hydraulic fluids, oil, pesticides with flammable 'carrier' fluids, grease or dust buildup are allowed to accumulate on the insulation blankets outboard of the passenger/cargo compartment linings. Some types of contaminates have been found to support propagation of flame.'

3 Federal Aviation Requirement (requirements of the US Federal Aviation Administration (FAA))

4 Minimum flame temperature of 843°C (1,550°F)

It recommended that operators periodically inspect and remove any blanket contamination. This Service Letter was amended on 6 August 2004 and was referenced in the ‘Zonal Inspection Program’ of the aircraft manufacturer’s maintenance planning document (MPD).

1.6.4 Smoke detection and cooling system in the MEC

A smoke detector is connected to the supply and vent lines of the forward equipment cooling and ventilation systems within the MEC. When it detects smoke the cooling system and ventilation system transition to override mode. In override mode the fans shut down and a valve opens to allow differential cabin pressure to reverse the flow of the cooling and ventilation systems by sucking air overboard. On the ground, with zero differential pressure, the override mode does not provide any cooling or active smoke clearing.

When smoke is detected and the override mode is activated an ‘EQUIP COOLING OVRD’ advisory message is displayed on the EICAS. However, no Master Warning, Master Caution or ‘smoke’ message is triggered.

1.6.5 Boeing 777 electrical power distribution and control system

The electrical power system on the Boeing 777 supplies 115 volt AC⁵ and 28 volt DC electrical power. The main power sources are an APU generator, a left integrated drive generator (IDG) and a right IDG; these are driven by the left and right engines respectively. All three main generators can supply up to 120 kva each of power. Two external power connectors can supply 90 kva each for ground operations. The backup power sources consist of two 20 kva backup (BU) generators, a ram air turbine (RAT) generator and the main battery.

The electrical power system normally operates as two independent left and right power channels. Each channel has a Main AC Bus. During normal flight operations the Left Main AC Bus receives power from the left IDG and the Right Main AC Bus receives power from the right IDG. On the ground, the APU generator or external power sources can be used to provide power to both main buses. A top level schematic of the power distribution system is shown in Figure 4 (a complete schematic is included in Appendix A).

An Electrical Load Management System (ELMS) distributes, monitors and protects the electrical power. It also supplies control logic for some aircraft systems. The ELMS replaces complex relay logic and circuit cards used on older aircraft. The ELMS components are in the following power panels:

5 The generators supply three-phase AC power at 400 Hz.

- P100 Left power panel (containing the Left Main AC bus)
- P200 Right power panel (containing the Right Main AC bus)
- P300 Auxiliary power panel
- P110 Left power management panel
- P210 Right power management panel
- P310 Standby power management panel
- P320 Ground service/handling power panel

The generated main and backup power is supplied directly to the left, right or auxiliary panels. These power panels supply power directly to devices requiring large loads (25 Amps or more) and supply power to the power management panels. The power management panels supply power to devices requiring smaller loads (less than 25 Amps). The power management panels contain processors that monitor loads and control many switching components. The left and right power panels (P100 and P200) contain the left and right Main AC buses and contain the main circuit breakers, including large breakers called contactors.

The flow of power from the main power sources is determined by the state of contactors. These contactors are electrically operated switches which open and close, and they can handle large amounts of current. Seven of the main contactors are shown in Figure 4; these are the LGCB, RGCB, LBTB, RBTB, APB, SEPC and PEPC (described below). The RGCB and RBTB (outlined in red), which were destroyed in this accident, are physically co-located within the P200 panel, one above the other.

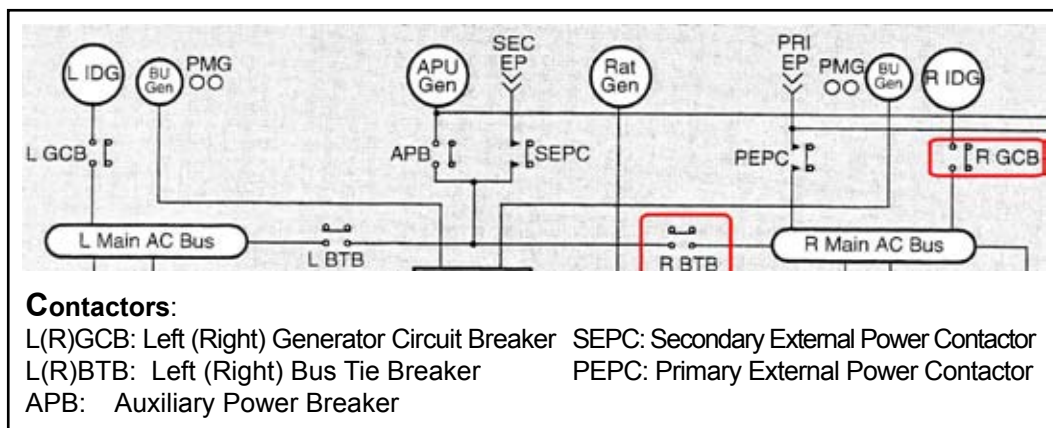

Figure 4

Boeing 777 electrical power distribution schematic

1.6.5.1 Contactor control

Generator Control Units (GCUs) and a Bus Power Control Unit (BPCU) monitor, protect, and control switching of the Main AC Buses. The Left GCU (LVCU) controls the opening and closing of the LVCB and LVTB. The Right GCU (RVCU) controls the RVCB and RVTB. The APU GCU (AVCU) controls the APB. The BPCU controls the PEPC and SEPC. All control units communicate with each other via an ARINC 629 bus.

The GCUs also control their respective generator's voltage and, during ground operations, synchronize the generator's frequency to a reference frequency for a no-break power transfer. The LVCU and RVCU also control the left and right Generator Control Relays (GCRs) which are used to de-excite the generator fields to stop power being produced by the generators.

1.6.5.2 Power transfers

During flight, if the power supply to a bus is transferred (eg following an IDG or engine failure), then a break transfer occurs. A break transfer is a transfer of power involving a brief interruption in the power supply. This can cause displays to momentarily blank and cause some systems to reset. On the ground, power transfers are routine, so the electrical system will attempt to make a no-break power transfer (NBPT) to avoid these issues. During a no-break power transfer there will be a brief period when two power supplies are simultaneously providing power to a bus – this is also referred to as parallel sources. The duration of parallel sourcing must be very short, otherwise the sources can become out of phase with each other, generating higher than rated currents.

1.6.5.3 No-break power transfer (NBPT)

A typical NBPT following engine start will occur as follows. After pushback the aircraft will have its APU running and all electrical power will be supplied by the APU generator. The APB, LVTB and RVTB contactors will be closed, enabling APU power to reach both main buses, and all the other contactors in Figure 4 will be open, as shown in Figure 5.

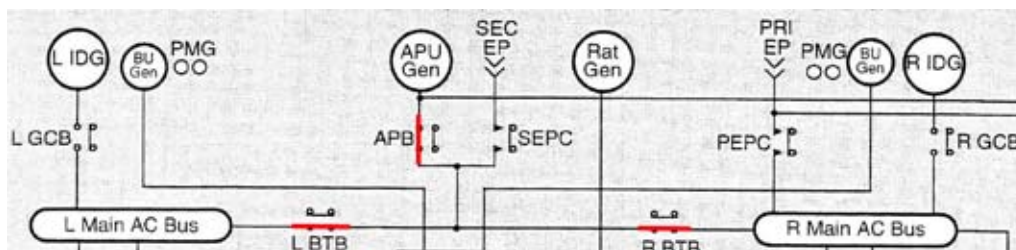

Figure 5

APU generator supplying both Main Buses; external power disconnected and engines off

The next step in the sequence is for an engine to be started. In the following example the right engine is started first. When the right engine N2 rpm reaches a value greater than or equal to $51.0 \pm 0.6 \%$ for 6 ± 1 seconds the right IDG will come online. This means that the R GCB will be commanded to close and afterwards the R BTB will be commanded to open to complete the NBPT, as shown in Figure 6.

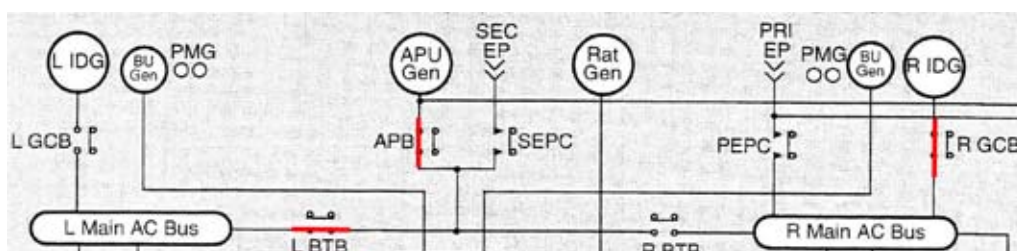

Figure 6

APU generator supplying Left Main Bus and right IDG supplying Right Main Bus

After the left engine is started the same NBPT will occur for the Left Main Bus and the LGCB will close followed by the LBTB opening. The APB will remain closed while the APU generator is on, so that the tie bus⁶ remains 'hot' enabling a rapid transfer of power in the case of an IDG fault or failure (see Figure 7).

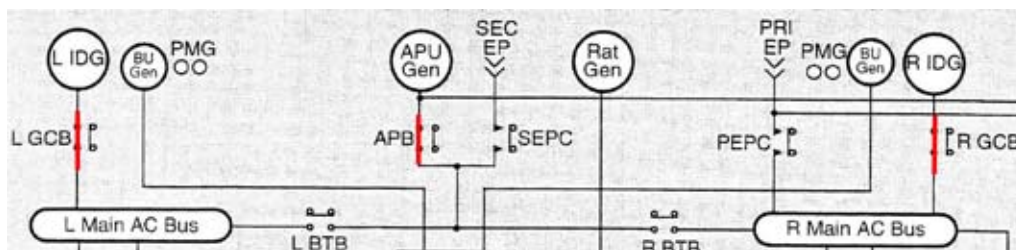

Figure 7

Left IDG supplying Left Main Bus and Right IDG supplying Right Main Bus. APU generator running but not supplying power.

⁶ The tie bus is the bus that connects the APB to the LBTB and RBTB.

A number of additional conditions beyond reaching the N2 rpm threshold must also be met for an NBPT to occur. These include the voltage and frequency of the two sources, and the voltage, frequency and phase angle differences between the two sources. To achieve these parameters the GCU will control the IDG and finely adjust its speed to match the frequency of the APU generator, which is fixed.

Once the NBPT parameters have been achieved the GCU will command the GCB to close. The GCB takes between 6 milliseconds (ms) and 20 ms to close after being commanded to close. The GCU will command the BTB to open 10 ms after commanding the GCB to close and will not wait for confirmation that the GCB has closed. The BTB takes between 6 ms and 20 ms to open after being commanded. Consequently, the maximum duration that two sources can be in parallel (ie GCB and BTB closed at the same time) is 24 ms, assuming no contactor faults (see Appendix B for NBPT timeline).

If the BTB fails to open after the GCB is closed the GCU will activate Sustained Parallel Source (SPS) protection after a set time period, of the order of tens of milliseconds. If the BTB was commanded to open but failed to open, the GCU will command the GCB to open and stay open (latch it open). If the BTB was not commanded to open, the GCU will command the BTB to open and latch open. If the BTB still does not open, the GCU will command the GCB to open and latch open.

1.6.6 Boeing 777 electrical power system protection

The electrical power system is designed to isolate a fault or failed device selectively while minimising power interruption to functioning systems. The design is multi-layered and includes load circuit breakers (thermal devices), bus distribution circuit breakers, GCBs and BTBs. These devices provide protection under the following scenarios:

1. A fault downstream of a load circuit breaker should trip the load circuit breaker.
2. A fault between a load distribution circuit breaker and a load circuit breaker should trip the load distribution circuit breaker.
3. A fault between the BTB and a load distribution breaker should trip the BTB.
4. A fault between the GCB and BTB should trip the GCB.
5. A fault between the generator and the GCB (ie in the power feeder cables) should remove the generator from powering the circuit.

Faults within a Main bus are addressed by three main protection features: (1) Unbalanced Current Protection, (2) Through Fault Protection, and (3) Under-voltage Protection. A fault at the generator or within the power feeder cables from the generator is addressed by Feeder Differential Fault Protection.

- 1) Unbalanced Current Protection is triggered when the difference in current between any two phases is greater than approximately 100 Amps. This could be caused by a short-circuit within one phase. The trip time is in accordance with an inverse time versus current curve (i.e. the higher the current the shorter the trip time). For example, at the contactor rating of 385 Amps, the trip time is approximately 10 to 30 seconds. For currents above this the trip time is shorter and for currents below this, the trip time is longer (for a current difference of 100 Amps the trip time is approximately 16 minutes). Unbalanced Current Protection will trip⁷ the BTB followed by the associated GCB and GCR, thereby removing all power sources to the affected bus.
- 2) Through Fault Protection is designed to protect the opposite bus when a fault occurs. It is triggered when the voltage measured at the bus is less than approximately 100 V and the current of any single phase is greater than approximately 500 Amps. Through Fault Protection will trip the appropriate BTB within a minimum of 7 seconds if the BTB was closed or will latch the BTB open within 8.5 seconds if the BTB was open.
- 3) Under-voltage (UV) Protection is available in two different levels. The first level, UV1, addresses bus faults that are not addressed by Unbalanced Current Protection or Through Fault Protection. UV1 will trip the appropriate GCB and GCR within a minimum of 9.5 seconds if the bus voltage drops below approximately 100 V. The second level, UV2, addresses faults within the generator which were not an issue in this accident.

The time delays allocated to the fault protection functions are designed to allow thermal circuit breakers and load distribution circuit breakers adequate time to clear a downstream fault before tripping the GCB or BTB which will remove power from the bus and thereby remove all power from downstream distribution legs.

⁷ The word 'trip' is used in discussions of protection logic but it means the same as 'open'.

Feeder Differential Fault Protection protects the power feeder cables between the generators and the power panels. The system measures the current at the generator end and measures the current at the power panel end using current transformers (CTs). The current at both locations should be the same. If a difference is detected it assumes a short circuit within the power feeder cable and will trip the GCB and GCR.

The electrical system permits operation between 347 Amps and 385 Amps for up to 4 minutes before it starts to shed loads, so a 'normal' operating current is less than 347 Amps. The worst case sub-transient⁸ peak current that could possibly be generated from a dead short was between 2,200 Amps and 2,600 Amps, supplied from the IDG depending on loading.

1.6.7 Contactor description (model ELM 827-1)

The GCBs, BTBs and APB on the Boeing 777 are Tyco Electronic contactors with part number ELM 827-1. This contactor is a three-phase magnetically latched switch rated at 385 Amps at 115 V AC at 400 Hz. It is designed to operate between -15°C and +70°C ambient temperatures and has been tested for up to 50,000 cycles (where one cycle consists of one opening and one closing operation) under full rated load and up to 100,000 cycles in mechanical testing. It is shaped almost like a cube, measuring 106 x 106 x 93 mm, with six external plungers as shown in Figure 8.



Figure 8

ELM 827-1 contactor showing the six external plungers



Figure 9

Contacting mating point on the power panel

⁸ The sub-transient state short circuit current is the initial short circuit current that occurs during the first half cycle of a fault (current varies as a sinusoidal curve in AC power).

The contactor is mated to the power panel (shown in Figure 9) via four screws and a serial connector. The six gold-plated plungers⁹ on the contactor are spring-loaded and compress against the six gold plated mating junctions on the panel when the contactor is attached. There are two plungers per phase (an input and an output) and there are three phases A, B and C. The internals of the contactor are shown in Figure 10 with the aluminium cover case removed.

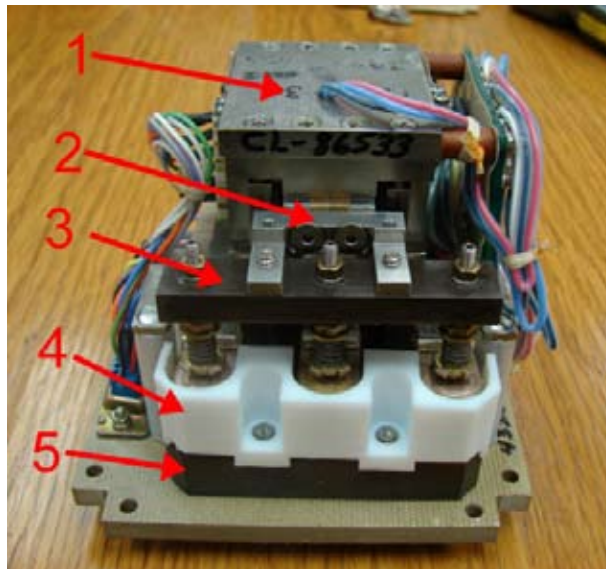

Figure 10

ELM 827-1 contactor with case removed: (1) electro-magnet motor;
(2) armature; (3) movable contact support bar; (4) arc chute;
(5) stationary contact support block

The main contacts are protected by an arc chute and are visible in Figure 11 where the arc chute has been removed. The stationary contacts are fixed to a support block while the movable contacts are connected to a movable support bar and armature that moves up and down. A 28V DC electrical current passing through an electro-magnetic coil is used to actuate the armature. Once the armature has moved, the actuating coil voltage is removed, and a permanent magnet holds the armature in the new position. The movable contacts are thus electrically actuated, but magnetically held in either the open or closed position. When the movable contacts are in the closed position individual pre-compressed springs allow force to be applied against the stationary contacts. As the surfaces of the main contacts wear due to erosion the spring continues to apply a force until the amount of ‘over-travel’ has been used up. The ‘over-travel’ gap is measured at (1) in Figure 11 and is factory set

⁹ The plungers are made of copper with fine silver contacts brazed on the external end. The whole assembly is then gold-plated.

to be between 0.018 and 0.032 inches. The spring is designed to provide a minimum 2.5 lb contact force as long as the ‘over-travel’ gap remains greater than 0 inches.¹⁰

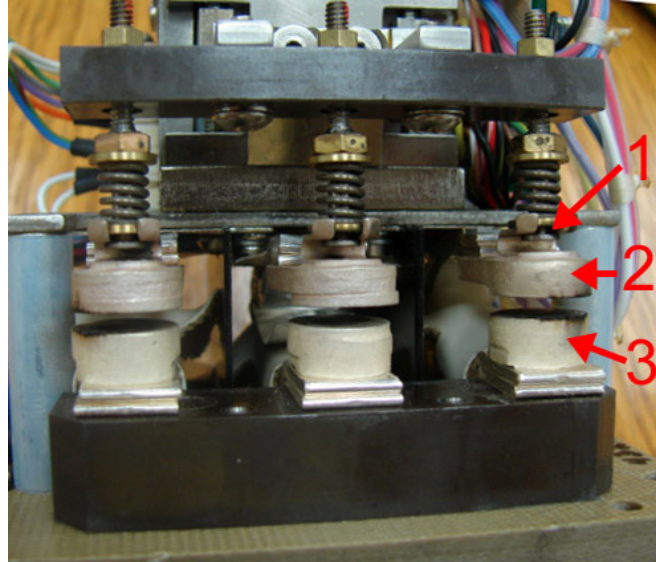

Figure 11

Contacter with arc chute removed and main contacts open:
(1) Spring over-travel gap measured here; (2) movable main contact;
(3) stationary main contact

The main contacts are made of silver cadmium oxide (80% silver and 20% cadmium oxide). The silver is used for its high conductive properties and cadmium oxide is used to reduce erosion and resist welding. The six main contacts are connected to the six plungers via silver pigtail foils. The silver pigtail foils consist of stacks of fine sheets of silver, 0.001 inches thick, which are wrapped together to form a conductive path capable of supporting 385 Amps. Foils are used to make the conductive path flexible. A top view of the contactor base plate in Figure 12 shows the silver pigtail foils connected to the stationary contacts. A similar connection is made between the pigtail foils and the movable contacts but is not shown in the Figure. Each pigtail foil is connected to a plunger via a screw and lockwasher. The plungers are retained by large nuts. Insulating silicone sheets are wrapped around the pigtail foils, but there is no insulation between the plunger nuts, apart from the insulating melamine base plate material.

¹⁰ The over-travel gap is measured with the contacts in the closed position. A gap will only exist if the armature bar has moved sufficiently to overcome the 2.5 lb pre-set spring force. A minimum factory-set ‘over-travel’ of 0.018 inches means that the contact surfaces would need to erode by 0.018 inches before contact force was lost.

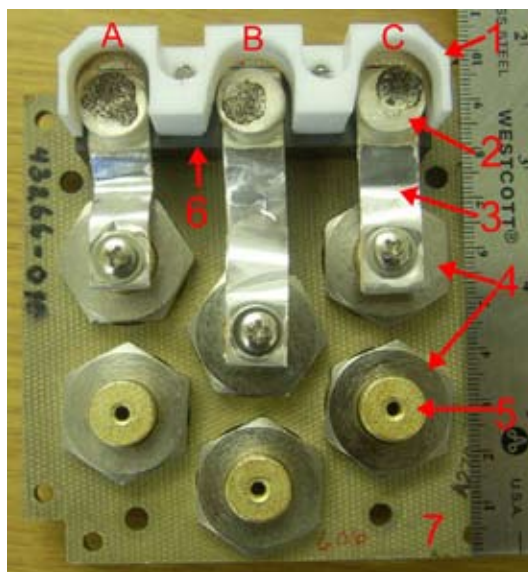

Figure 12

Contactor base plate: (1) arc chute; (2) stationary contact; (3) silver pigtail foils; (4) plunger nuts; (5) plunger; (6) stationary contact support block; (7) melamine base plate. The silicone insulation sheets around the pigtail foils have been removed in this photo. The pigtail foils for the movable contacts connect to the rear plungers (5)

The materials used in the contactor have changed over the years since first manufacture. The RGCB and RBTB on N786UA had melamine base plates and Teflon arc chutes as shown in the Figures here. However, they had the earlier stationary contact support block made of melamine instead of the brown Ryton support block shown in the Figures. Around February 1997 the base plate and contact support block were changed to a single-piece molded Dielectrite. In December 2000 the arc chute was changed from Teflon to Zytel FR-10 and then to Ryton in January 2007. The properties of these materials are included in section 1.16.10.

Another change to the contactor design early in its production cycle was a re-positioning of the arc chute. The first contactors had an arc chute positioned as in the lower image in Figure 13, which enclosed the full diameter of the main contact. Due to issues with contacts rubbing against the arc chute, the arc chute was re-positioned in later models as shown in the upper image of Figure 13. In the new position the arc chute does not fully enclose the diameter of the contactor. The contactor manufacturer's records made it difficult to pinpoint exactly when the changeover occurred, but the RGCB and RBTB contactors on N786UA were probably fitted with an arc chute in the new position.

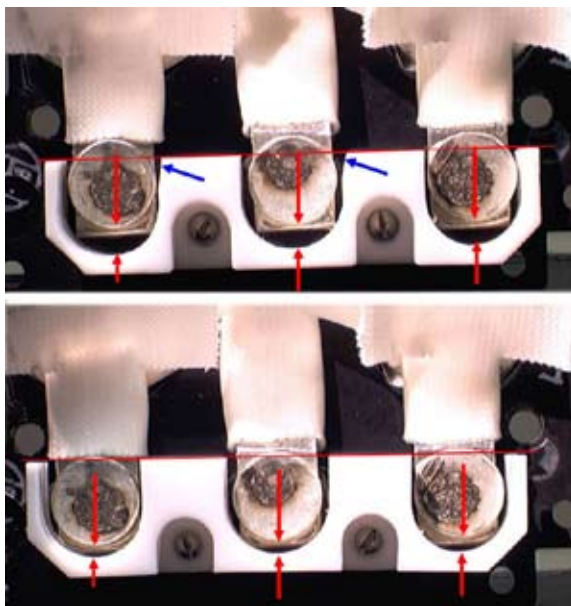

Figure 13

Top image: Position of arc chute on current contactors.

Lower image: Position of arc chute on early contactor designs.

Red arrows indicate change in gap. Blue arrows indicate additional modified corners.
 (Note: the silicone insulation sleeves around the pigtail foils are visible here)

The ELM 827-1 contactor contains a set of 11 auxiliary contacts: 5 auxiliary contacts within one actuation block and 6 auxiliary contacts within an actuation block on the opposite side of the contactor (see Figure 14). The auxiliary contacts are small switches that either open or close as the main contact opens and closes. Some auxiliary contacts will indicate a closed circuit when the main contacts are closed and others will indicate an open circuit. The auxiliary contacts are used to communicate the state of the main contacts to external systems such as the GCU's. All contactors have at least two auxiliary contact switches that communicate main contact state, in order to provide redundancy. The RGCB uses four auxiliary contacts to transmit its contact state via separate wires to all three GCUs and the BPCU. The RBTB uses two auxiliary contacts to transmit its contact state via separate wires to the RGCU and BPCU¹¹. One set of auxiliary contacts, called the throat cutter switch, is used to remove power from the actuation coil, once the main contacts have moved towards either the open or closed position.

¹¹ The GCUs and BPCU also communicate with each other over an ARINC 629 data bus to monitor contactor state.

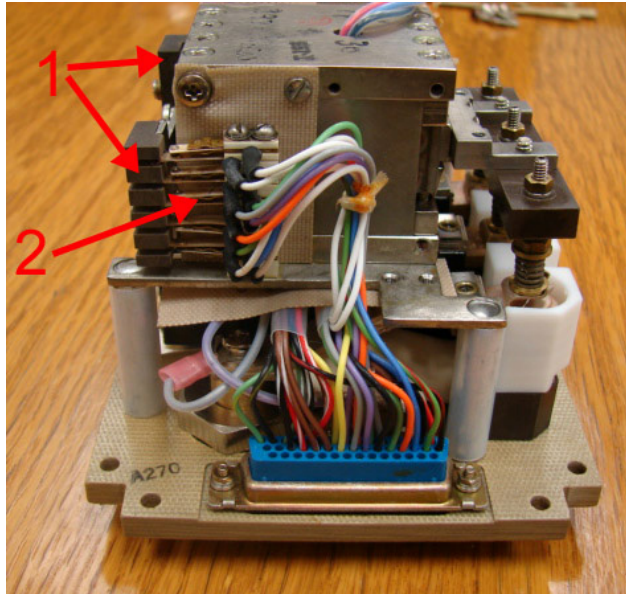

Figure 14

Side view of contactor: (1) auxiliary contact actuation blocks;
(2) auxiliary contact blades

The PEPC and SEPC contactors have a different part number, namely ELM 828-1/-2. These are similar to the ELM 827-1 contactors except for the latching mechanism which holds the contacts in position using an electro-magnet rather than using a permanent magnet, and some differences in signal wiring and in the number of auxiliary contacts.

1.6.8 Electrical system principles of heat and resistance

A critical feature within an electrical system and within the contactors is junction resistance. Every circuit junction has a resistance and the greater the resistance the greater the heat generated at that junction. According to Ohm's law, voltage is equal to resistance multiplied by current ($V = I R$). The power or heat generated in a resistive element is equal to the voltage across it multiplied by the current through it ($P = VI$); or using Ohm's law this can be converted to the current squared times the resistance ($P = I^2 R$). The contactors are handling large currents and since current is squared, even small resistances encountered can generate large amounts of heat. A junction with a resistance of 0.001 ohms with a current of 385 Amps passing through it will generate 148 Watts of heat.

The electrical resistance between contact faces is a function of the hardness of the material and the contact force. The greater the contact force and the lower the hardness the less resistance there is. Therefore, any loss of contact force will result in greater resistance and greater heat generated.

Contact resistance can also be affected by contamination. If insulating materials contaminate the contact surfaces this can increase the contact resistance and the heat generated.

In contactor acceptance bench tests the resistance across the contact junctions is measured by passing 385 Amps through the contactor using a very low voltage. The voltage drop across each junction is then measured (in millivolts, mV). The lower the voltage drop measured, the lower the resistance. The maximum permitted voltage drop across each phase, measured from plunger to plunger, was 225 mV¹².

1.6.9 General principles of arcing and arcing containment

Each time the main contacts in a contactor open or close, while energised, a small arc is usually generated. An arc will form immediately upon opening and then grow as the contacts are pulled apart. The energy of the arc and also the heat it produces is proportional to the length of the arc. The arc is extinguished when the voltage reaches zero Volts¹³ beyond a critical distance. Therefore, the speed at which contacts open is important as too fast will give long high energy arcs and too slow will mean that the critical distance is not reached before the first zero voltage is passed. The critical distance or minimum gap to extinguish an arc depends on several factors including contact temperature, humidity, air pressure and surface shape. Furthermore, once an arc has formed, any residual ionised material generated by the arc can assist in restarting the arc. Therefore, defining the minimum contact gap to avoid arcing is not straightforward, but one reference lists a minimum arc distance in air of 0.03 mm for 280 V AC¹⁴. At 2,900 V this distance is still only 0.5 mm in air. When contacts close, an arc is also created but it tends to be of shorter duration than when contacts open and is mainly caused by contact bounce.

The ionised plasma¹⁵ that is created during the arc formed during normal opening and closing operations is not sufficient to cause arcing between other parts of the contactor, and a small vent in the contactor allows any build-up over time to vent out. However, if a failure occurs resulting in sustained high current short-circuits or arcs, sufficient plasma could build up within the contactor to trigger arcs across junctions that would not normally arc in air.

¹² In February 2007 this millivolt drop requirement was reduced to 175mV (see section 1.18.4.4).

¹³ This discussion concerns AC arcs and AC voltage is a sine wave that oscillates about zero Volts.

¹⁴ On-line calculator at www.cirris.com/testing/voltage/arc.html.

¹⁵ Plasma is an ionised gas that contains a certain proportion of electrons that are free and not bound to an atom or molecule; this makes the plasma electrically conductive.

The ELM827-1 contactor contains a device referred to by the manufacturer as an ‘arc chute’ (see Figure 10). Arc chutes are often used in circuit breakers and are intended to extinguish the arc as quickly as possible. Arc chutes function by breaking up the arc into small sections that cool and extinguish quickly and typically consist of stacks of electrically connected metal plates. The ‘arc chute’ in the ELM827-1 contactor is a machined block of Teflon¹⁶ that partly surrounds each pair of main contacts. It does not serve to help extinguish the arc and its main function is to contain the ionised plasma and any debris formed by arcing, and to prevent this plasma or debris from forming a bridge between two phases. It also provides an electrical insulation barrier between phases. The ‘arc chute’ is more appropriately referred to as an ‘arc barrier’, but the term ‘arc chute’ is used in this report as it is the name assigned by the contactor manufacturer.

Arcing also causes contact surface erosion and therefore materials such as silver cadmium oxide are used on the surfaces of contacts to minimise the degree of erosion and resist welding.

1.6.10 Number of contactor cycles per flight

The number of contactor cycles per flight depends on what combinations of primary external power, secondary external power and APU power are used before engine start and after engine shutdown. A typical scenario would involve starting the APU while on primary external power, disconnecting primary external power, and then starting the engines on APU power. If one assumes that this scenario is then reversed at the destination airport, the RGCB, LGCB and LBTB will transition twice, the APB will transition four times, and the RBTB will transition 6 times. One cycle consists of two transitions, so the typical contactor cycles per flight are: RGCB (1), LGCB (1), LBTB (1), APB (2) and RBTB (3). N786UA had completed 6,622 flight cycles, so the RGCB contactor can be estimated to have completed 6,622 cycles and the RBTB to have completed about 19,866 cycles. However, if the APU was left running on the ground or if secondary external power was used on some occasions, then the total RBTB cycles would be less than this estimate, but the RGCB cycles would remain unchanged.

1.6.11 Differences between ELMS 1 and ELMS 2 power panels

The aircraft N786UA was equipped with the first version of ELMS called ELMS 1. Later models of Boeing 777 aircraft were equipped with ELMS 2 power panels in place of the earlier ELMS 1 design. The main reasons

¹⁶ Later models used machined blocks of Zytel FR-10 instead of Teflon and models since January 2007 used Ryton.

for ELMS 2 were electronics improvements, parts obsolescence, weight reduction, and the generation of more space for additional relays and circuit breakers. A significant change to the ELMS 2 power panels was a change in backplane material. The ELMS 1 power panels contained a melamine sheet as its insulating backplane material. This material was changed to FR-4 in the ELMS 2 power panels, which was a less expensive material than melamine, but had a lower dielectric breakdown¹⁷ temperature.

1.7 Meteorological information

The recorded meteorological conditions at 0950 hrs were: Wind 310° at 12 kt (variable between 270° and 350°). Visibility greater than 10 km. Broken cloud at 3,500 feet. Temperature 9°C. Dewpoint 2°C. QNH 1013 mb.

1.8 Aids to navigation

Not applicable.

1.9 Communications

All communications with the aircraft were by VHF radio or by ground personnel via headset. No problems were encountered.

1.10 Aerodrome Information

Not applicable.

1.11 Flight recorders

1.11.1 General

The solid-state Flight Data Recorder (FDR)¹⁸ and solid-state Cockpit Voice Recorder (CVR)¹⁹ were removed from the aircraft and replayed at the AAIB; both had retained recordings of the event. The aircraft had been equipped with a Quick Access Recorder (QAR) but this was unserviceable at the time. Had it been operational, the QAR would have provided some recorded data at much shorter sample intervals than that provided on the FDR. Early in this investigation the aircraft operator determined that the cause of this un-serviceability had been an intermittent fault within the QAR itself. The Generator Control Units (GCUs) and Bus Power Control Unit (BPCU)

¹⁷ Dielectric breakdown refers to a loss of its insulating properties.

¹⁸ FDR part number 980-4700-042, serial number 4711.

¹⁹ CVR part number 980-6020-001, serial number 2645.

contained recorded error messages in Non-Volatile Memory (NVM); these messages were retrieved and are also presented in this section.

1.11.2 Flight recorder operation

The half-hour CVR recording commenced prior to the pushback from Stand 318 and terminated when power was removed from the aircraft, having taxied to Stand 364, and as the passengers began to disembark. The CVR recording started before the FDR recording and stopped almost four minutes after both engines had been shut down. The FDR began recording when the engines were started after pushback, stopped when both engines had been shut down, and comprised a total recording time of just under 12 minutes.

1.11.3 CVR installation

The CVR installation was of the ‘hot microphone’ type²⁰. Speech and RT²¹ communications from the first officer and third crew member (a relief first officer) were recorded satisfactorily. However, whilst RT communications from the commander were present on the recording, normal speech, via his boom microphone, was not. Therefore, it was necessary to obtain a transcript of the commander’s flight deck conversations from the area microphone recording. This did not significantly hamper the investigation as, with a relatively quiet flight deck environment, the commander’s speech was reasonably discernible.

As part of this investigation, the operator conducted extensive tests on the recorder and the CVR installation in order to establish the reason for the problem with the recording of the commander’s speech. No anomaly was found and it was not possible to replicate the fault. A search of the maintenance records for the CVR revealed that no repairs to that unit had been initiated. The unit was returned to service and no further faults have been reported.

1.11.4 FDR electrical system parameters

The FDR recorded data from a comprehensive set of aircraft parameters which included a number pertinent to the operation of the aircraft’s electrical system. Of particular interest to this investigation were the AC output voltage, frequency and loading associated with each of the IDGs. Unfortunately, the interval between successive samples of these electrical system parameters was

20 In a ‘hot microphone’ installation the crew microphones are always live and provide a more intelligible recording than the alternative installation type in which crew conversations are only recorded from the cockpit area microphone, together with any ambient noise.

21 RT refers to ‘Radio Telephony’ communications over the radio, rather than over the intercom.

64 seconds²² and thus exact timings for changes in their values could not be made. No anomalies were observed in the values of parameters associated with the DC power supply buses or either of the main AC supply buses on the aircraft.

1.11.5 FDR warning parameters

The FDR recorded the status of many aircraft warnings. Of particular note were those associated with the detection of smoke in the MEC, forward cargo, aft cargo, crew rest areas and the lavatories. Smoke was detected in the MEC and this was recorded as an 'EE Bay Smoke Warn' discrete²³. No smoke warnings were triggered for any of the other areas of the aircraft during this event.

The FDR recorded two instances of a Master Warning but there was no associated aural alert tone recorded on the CVR in either case. All events which would have led to a Master Warning indication, with the sole exception of windshear detection, would have caused the Warning Electronic System (WES) to generate an aural alert which would have been recorded on the CVR. In the case of the predictive windshear detection warning, it was the weather radar itself which was designed to generate the audible alert rather than the WES. The routing of the wire carrying the windshear detection signal was through the P205 electrical panel – an area affected by fire damage. Therefore it is considered likely that both Master Warning events recorded by the FDR were spurious and were caused by fire damage to the windshear signal wire from the P205 panel.

1.11.6 Recorded fault messages from GCUs and BPCU

The Left, Right and APU GCUs and the BPCU were removed from the aircraft and taken to the manufacturer for a bench test and download of the NVM. The NVM for the AGCU and LGCU did not contain any fault messages for the period of the failure event. The RGCU and BPCU contained several fault messages for the period of the failure event. These are presented below with an explanation of the meaning of each message. The times listed are the times that the message was generated, which in some cases was a few seconds after the fault was first detected.

22 The recording system, the full parameter details of which are contained in the aircraft manufacturer's document D247W018-8 rev. C, was compliant with the performance requirements applicable at the time.

23 The Main Equipment Centre (MEC) is also sometimes referred to as the Electrical Equipment (EE) bay and the aircraft manufacturer has used this specific name for the 'EE Bay Smoke Warn' parameter.

1000:46 BPCU: RGCB CLOSE AUX DISAGREE

This message means that the RGCB has been commanded to close and the RGCB auxiliary contact to the RGCU indicates closed, but the auxiliary contact to the BPCU indicates open (condition required for 1.5 ± 0.5 seconds).

1000:57 BPCU: RIGHT MAIN BUS PHASE C OPEN WIRE

This message means that the BPCU has detected that the main bus phase C voltage has been less than 20V for 10.5 ± 0.5 seconds²⁴.

1000:57 RGCU: RGCU MAIN BUS PHASE C FAULT

This message means that the contactors are closed in such a configuration that the right main bus should be powered, but the RGCU has detected that the main bus phase C voltage has been less than 20V for 10.5 ± 0.5 seconds.

1001:02 RGCU: RGCB CLOSE FAULT

This message means that the RGCB auxiliary contact to the RGCU indicates open even though the last command was for the RGCB to close (condition required for 0.15 seconds).

1001:04 RGCU: RIGHT FEEDER DIFFERENTIAL PROTECTION

This message means that the RGCU has detected a difference in current between the generator Current Transformer (CT) inside the IDG and the CT at the feeder connection of the P200 panel (near the RGCB) of 40 ± 7.5 Amps for 0.06 ± 0.02 seconds. This message will cause the RGCB to be commanded to trip.

1001:04 RGCU: RGCB TRIP FAULT

This message means that the RGCB was commanded to trip, but the RGCB auxiliary contact to the RGCU indicates closed (condition required for 0.07 seconds).

1001:07 RGCU: RBTB TRIP FAULT

This message means that the RBTB was commanded to trip, but the RBTB auxiliary contact to the RGCU indicates closed (condition required for 0.07 seconds).

1001:15 RGCU: RGCU TIE BUS PHASE C OPEN WIRE

This message means that the RGCU has detected that the Tie Bus phase C voltage has been less than 20V for 10.5 ± 0.5 seconds,²⁵ when the Tie Bus was expected to be powered based on the system configuration.

²⁴ Both the BPCU and RGCU measure the right main bus voltage inside the PEPC at the C phase.

²⁵ This tie bus voltage is measured inside the RBTB.

1001:17 BPCU: GSTR DISAGREE

This message can mean different things but relates to the GSTR²⁶ auxiliary contact state and relay driver command (condition required for 5.5 seconds).

1001:43 RGPU: 28 VOLT SWITCH POWER FAULT

This message means that the RGPU has detected an over-current on the 28V line which powers the contactor coils in the RBTB and RGCB (condition required for 1 second).

Detailed analysis of the NVM fault messages is presented in Appendix C and discussed in Part 2 (Analysis) of this report.

1.11.7 Summary of relevant data recorded during the event

Information from the FDR, CVR and fault messages from the GCUs' NVM were time-correlated. A summary of the relevant FDR, CVR and NVM data are presented below with some additional information from flight crew interviews. The pertinent FDR parameters with annotated CVR and NVM information is presented in Figure 15 and a timeline of events is included in Appendix D.

At 0955 hrs the ground handlers confirmed that they had completed their checks and the cabin crew armed the doors in preparation for departure. The pushback from stand 318 was uneventful. The start sequence was initiated on both engines almost simultaneously and, as they began to spool up, the ground handlers confirmed that the pin and towbar had been removed. At 1000:35 hrs the right engine N2 reached 51.4% and at 1000:37 hrs the output voltage from the right IDG indicated 115V. At 1000:41 hrs (plus or minus one second) the RGPU would have started a NBPT by closing the GCR and RGCB. At 1000:44 hrs²⁷ the BPCU detected a disagreement in the RGCB's auxiliary contact state. Within two seconds of this failure detection, an unusual noise became discernible on the area microphone channel recording. This noise was subsequently described by the crew as being like a low-pitched 'growling' in nature, but was intermittent and was comprised of many different frequencies²⁸. At the same time both the BPCU and RGPU detected an under-voltage of the Right Main Bus.

²⁶ GSTR (Ground Service Transfer Relay) is also known as the GSR (Ground Service Relay). The term GSR is used later in this report.

²⁷ The time '1000:44' is taken in this report to be the time of the failure event.

²⁸ The area microphone records frequencies between 150 Hz and 6 KHz. A low 'growling' noise could be in the region of 30 to 40 Hz.

At 1000:48 hrs the first officer said “TWO GOOD STARTS” and then said “SOMETHING HAPPENED” just as four warning tones, corresponding to a Master Caution alert²⁹, were heard. He then made a reference to the fact that his Primary Flight Display and Navigation Display had flickered off and on. At 1001:02 hrs the RGCU detected another fault with the RGCB’s auxiliary contact state, and two seconds later the RGCU detected a third RGCB fault, and an under-voltage of the Tie Bus. At the same time the RGCU activated ‘Differential Feeder Protection’ which tripped the right IDG exciter field and commanded the RGCB to open. At 1001:06 hrs, 22 seconds after the electrical failure event, the first officer commented that the Right Main Bus was unpowered and also observed that the EICAS display was scrolling through multiple advisory messages. A member of the cabin crew contacted the flight deck using the intercom and was advised that it was not a serious problem and that the flight crew were working on the issue.

At 1001:26 hrs, as the crew selected the electrical system page on the EICAS display, the CVR recorded the sound of cooling fans powering down. Simultaneously the FDR recorded an ‘EE Bay Smoke’ warning. The next sampled values for the right IDG output frequency and electrical load were recorded on the FDR over the ensuing 5 seconds and were noted as being 0Hz and 0% respectively. The first officer commented that “THE WHOLE RIGHT MAIN BUS JUST CRASHED” and the commander requested that they go back to the checklist.

At 1001:43 hrs the last NVM fault message was recorded. As the flight crew followed the check list, they recycled the right generator control switch off and then on, noting that they were permitted to attempt only one reset. They also checked that the APU was on and at this point they may have recycled the Right Bus Isolation Tie switch once.

The crew decided that they wanted to get the aircraft back on stand. The relief first officer advised their company operations control centre that they had a maintenance problem whilst the commander called ATC to request a return to the gate due to a mechanical problem. At 1003:16 hrs, whilst they were both in conversation, the FDR recorded a Master Warning event but no associated aural tone was recorded on the CVR. By 1003:42 hrs, the low-pitched intermittent growling noise, which had been decreasing in volume, could no longer be heard on the CVR recording but, from crew comments, it may have still been audible on the flight deck³⁰.

29 This Master Caution aural alert was probably for the ‘ELEC AC BUS R’ failure message.

30 In interviews the flight crew could not remember exactly when the noise stopped.

At 1003:57 hrs there were sounds of the flight crew sniffing and comments about a bad smell. The commander stated in interview that it was an electrical burning smell while the first officer said he had smelt similar smells from the galley before. Shortly afterwards they observed on the overhead panel that the equipment cooling had gone into override mode. At 1004:15 hrs they discussed shutting down the right engine and eight seconds later the FDR recorded that the right engine fuel had been shut off. As the right engine was spooling down the FDR recorded a Master Warning indication for a period of 13 seconds and, as previously, there was no associated aural alert. The crew were advised to taxi to stand 364, a non-jetty stand in front, and to the left, of their current position. At 1004:47 hrs the flight deck door was opened and the senior cabin crew member advised that an electrical smell was present in the passenger cabin. The first officer and relief first officer advised her that they had a problem with the equipment cooling and the electrics but that there was no fire.

At 1005:14 hrs the commander was advised by the tug driver, who had left his tug and reconnected his headset to the interphone system, that there was a lot of smoke coming out of the vents. The crew wanted a tug to get them back onto their originating (Stand 318) but were told that, as the stand was behind them, this was not possible and that Stand 364 would be better. During this exchange the relief first officer made an announcement to the passengers, advising them that they had had an electrical problem which had shut down some of the air conditioning and equipment cooling. He also told them that maintenance were about to look at the problem with a view to resolving it as quickly as they could.

The crew continued to review the symptoms, which also included a reduction in the air conditioning flow rate, and brought up the pneumatic system status. The commander also expressed concern that he might not be able to taxi the aircraft with one engine shut down. At 1007:25 hrs ATC informed the crew that “QUITE A LARGE AMOUNT OF SMOKE” had been seen coming from one of the engines and, as a consequence, a ‘Local Standby’ had been placed on the aircraft with one fire appliance to remain in attendance once the aircraft had reached the stand. Following a brief discussion debating the merits of restarting the right engine, the commander elected to try to taxi to Stand 364 on just the left engine. Prior to moving he requested confirmation that he was not going to damage anything or anyone behind him. The aircraft started moving at 1008:55 hrs and was brought to a halt on stand 364 about one and a half minutes later. A further passenger announcement was made to advise that steps had not yet been brought up to the aircraft and that, once the seatbelt sign had been switched off, mobile phones could be used. At 1010:51 hrs, having checked that the APU was still running, the crew shut down the left engine.

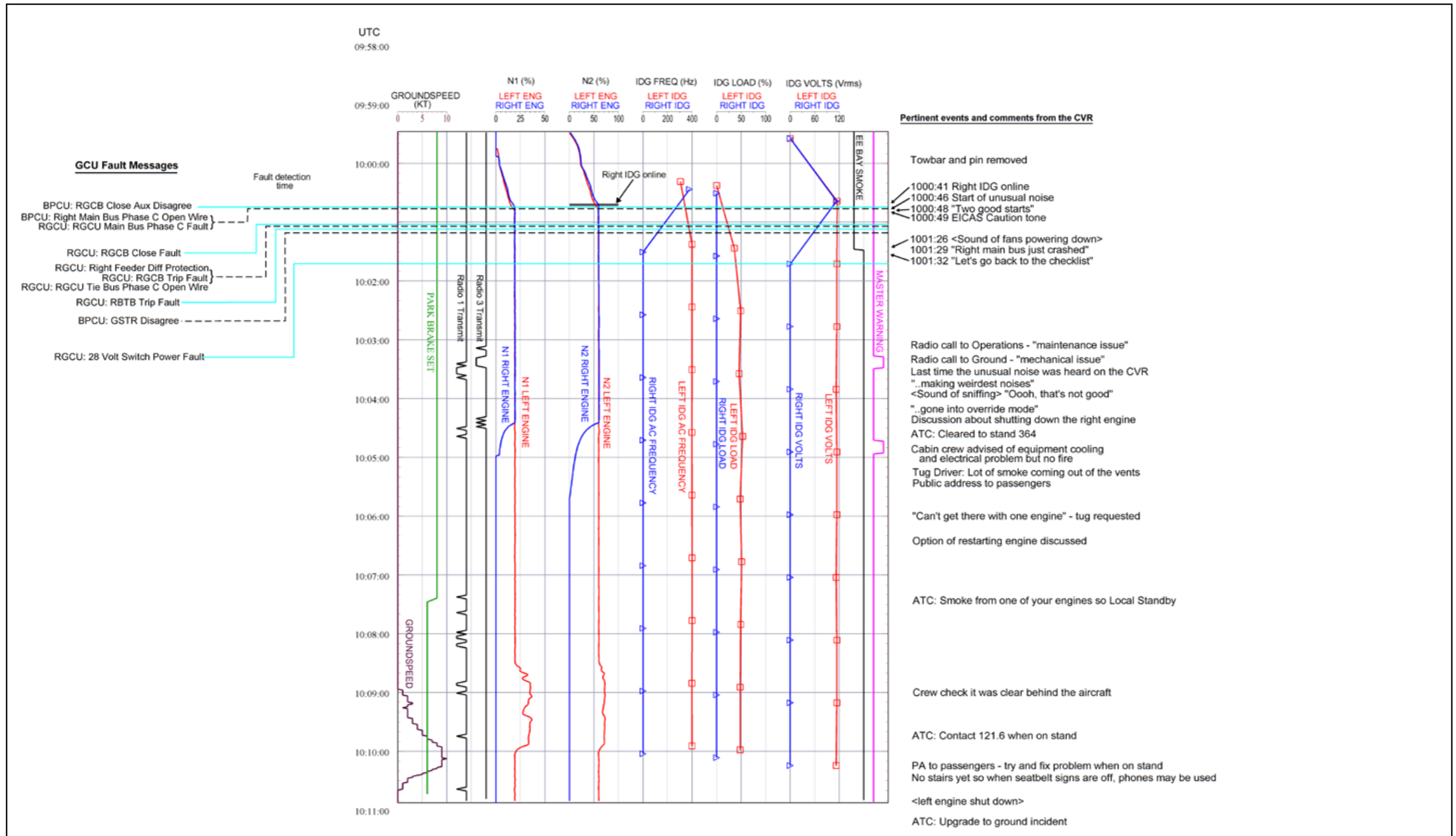

Figure 15

Pertinent FDR parameters with annotated CVR and NVM information

At 1011:13 hrs, as the crew were working through the parking checklist, they were advised by ATC that smoke had been seen coming from the avionics bay and that the event was being upgraded to an 'aircraft ground incident'. The fire service outside the aircraft advised that a fair amount of grey smoke could be seen coming from the area of the avionics bay and that the crew should deplane the passengers once steps had been brought up to the aircraft. The senior cabin crew member, having previously ordered all other cabin crew to move to and remain at their allocated doors, requested the disarming of door L2 only.

At 1013:00 hrs the commander made a final announcement to the passengers explaining that the fire service would be outside the aircraft to deal with the equipment overheat problem. He further requested that they leave all personal effects behind and disembark in an orderly manner. At 1014:23 the crew shut down the APU but left the main battery on. The CVR recording ended at 1014:41. After shutting down the APU and opening the flight deck window the flight crew observed smoke in the cockpit for the first time. The first officer turned the battery off after all passengers had disembarked.

1.11.8 Data prior to the event

In total, the FDR had retained nearly 54 hours of the most recently recorded data. This data was reviewed by the AAIB and by the aircraft manufacturer for any anomalies associated with the operation of the IDGs and AC electrical system prior to the N786UA accident, but none were found.

1.12 Aircraft examination

1.12.1 General aircraft examination

The insulation blankets behind, below and opposite the P200 power panel had suffered significant fire damage and some sections had charred to ash. Sections of the P200 power panel cover were coated in soot and the area covering the RGCB and RBTB exhibited blistering associated with heat damage (see Figure 16). The power cables connected to the P200 power panel were sooted and some exhibited minor heat damage of the coloured insulation sleeves, but none were damaged. The torque of the nuts connecting the power cables was measured and found to be satisfactory.

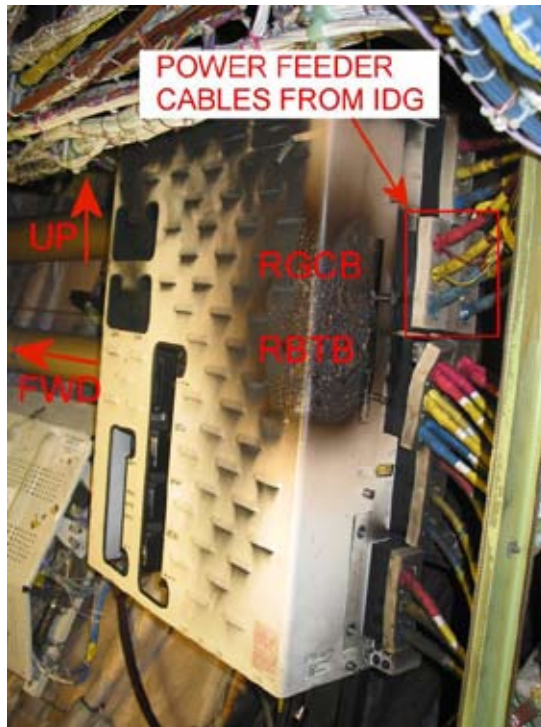

Figure 16

P200 power panel with cover installed. The location of the RGC B and RBT B behind the cover is annotated

Removing the P200 power panel cover revealed extensive heat and fire damage to the RGC B and RBT B contactors as previously depicted in Figure 2 of section 1.3 (page 5). The Ground Services Relay (GSR) located directly below the RBT B had a damaged and molten upper outer casing. There were small drops of molten metal on other parts within the power panel and on the insulation blankets.

The most extensive insulation blanket fire damage was directly below the P200 power panel as depicted in Figure 17. In this figure the P200 power panel cover has been removed and the floor panel which abuts against frame 'A' has also been removed. A wire bundle from the P205 panel, also shown in Figure 17, had some heat damage and possibly fire damage.

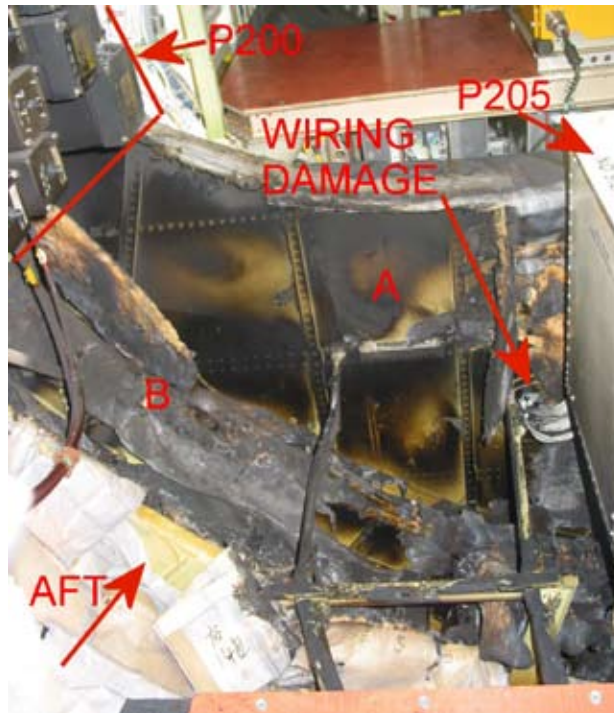

Figure 17

View looking aft with P200 power panel (cover removed) on the left and P205 power panel on the right. 'A' is one of the heat damaged frames. 'B' is a charred insulation blanket. The damaged wiring bundle is from the P205 panel

1.12.2 Structural damage examination

A detailed damage and structural survey was carried out by the aircraft operator with assistance from the aircraft manufacturer. No structural damage was found on the fuselage skin or nose gear bay pressure box. Conductivity measurements (eddy current) were used to assess structural weakening as a result of heat damage. Frame 'A' shown in Figure 17 exhibited the highest conductivity reading which corresponded to a reduction in material capability of 34%. This frame and some nearby frames and stringers had suffered sufficient heat damage to require replacement. The floor panel support structure also required replacement. Two equipment cooling ducts behind the P200 panel were heat damaged and heavily coated in soot; these also required replacement. A stabilizer control cable and a landing gear control cable behind the P200 panel were coated in soot and assessed to have been exposed to heat. The stabilizer control cable was part of the alternate (backup) stabilizer control system; the primary control was electric. The landing gear control cable was associated with the right main landing gear braking system. Failure of this cable would have resulted in an inability to release the right main gear brakes.

The aircraft manufacturer assessed that all the affected structural elements would have sustained in-flight pressure loads and ‘get-home’ limit loads³¹ if the heat damage had occurred in flight.

1.12.3 Wiring damage examination

A number of wire bundles from the P205 panel had suffered heat damage where they passed through a hole in the bulkhead aft of the panel. This is the area labelled as ‘Wiring Damage’ in Figure 17 and a close-up of this damage is shown in Figure 18. A number of these wires had insulation heat damage and were coated in soot. Some wire ties had burnt and bundle clamps had melted. A close examination of the wires at the bulkhead did not reveal any which had suffered sufficient insulation damage to expose the conductive wiring. However, a few wires higher up in the bundle, which were in direct physical contact with an insulation blanket, had insulation that had completely burnt away, exposing its conductive wiring. Some faults detected on the FDR were consistent with wire damage from the P205 panel (see section 1.11.5, page 26), although no associated circuit breakers had been tripped.



Figure 18

Wiring bundles from P205 panel (close-up of area labeled ‘Wiring Damage’ in Figure 17)

31 The ‘get home’ limit loads are loads that are unlikely to be exceeded during a flight back to an airport when the flight crew are aware of damage to the aircraft. These limit loads are defined in FAA Advisory Circular AC 25.571-1C (Damage Tolerance of Structure), and include 70% of limit flight manoeuvre loads and 40% of limit gust velocity.

1.12.4 Insulation blanket examination

The insulation blankets around the P200 panel area were removed from the aircraft and sent to the U.S. National Transportation Safety Board (NTSB) where their fire investigators conducted an initial visual examination. The insulation blankets were then sent to the aircraft manufacturer for a detailed examination in their materials laboratory. A top view schematic of the insulation layout in the aircraft is shown in Figure 19. The insulation blankets were identified using a combination of visible part numbers, comparisons to drawings, and comparison to photographs taken on the aircraft. A composite photograph of the identified insulation blankets is shown in Figure 20. The blank areas are areas where the insulation was either completely burned, too charred to identify, or missing.

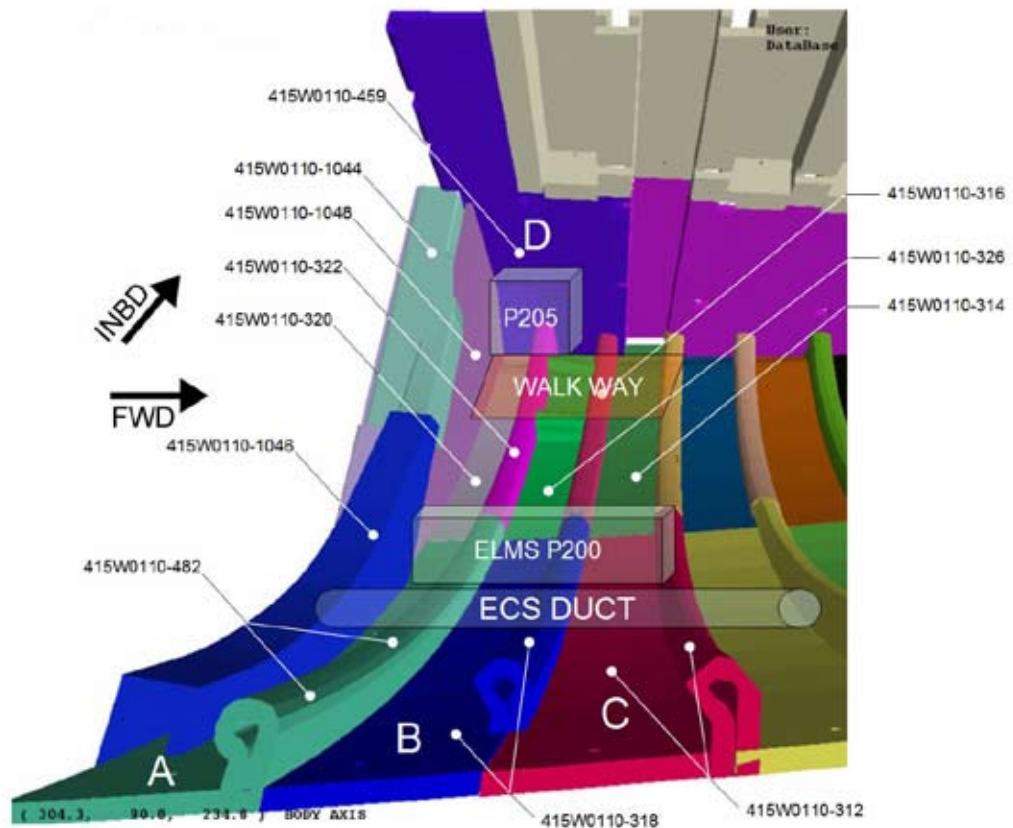

Figure 19

Top view schematic (looking down on to top of P200 panel) showing layout of insulation materials sections A, B, C and D (walkway floor panel, P200, P205 and ECS duct are not drawn to scale)

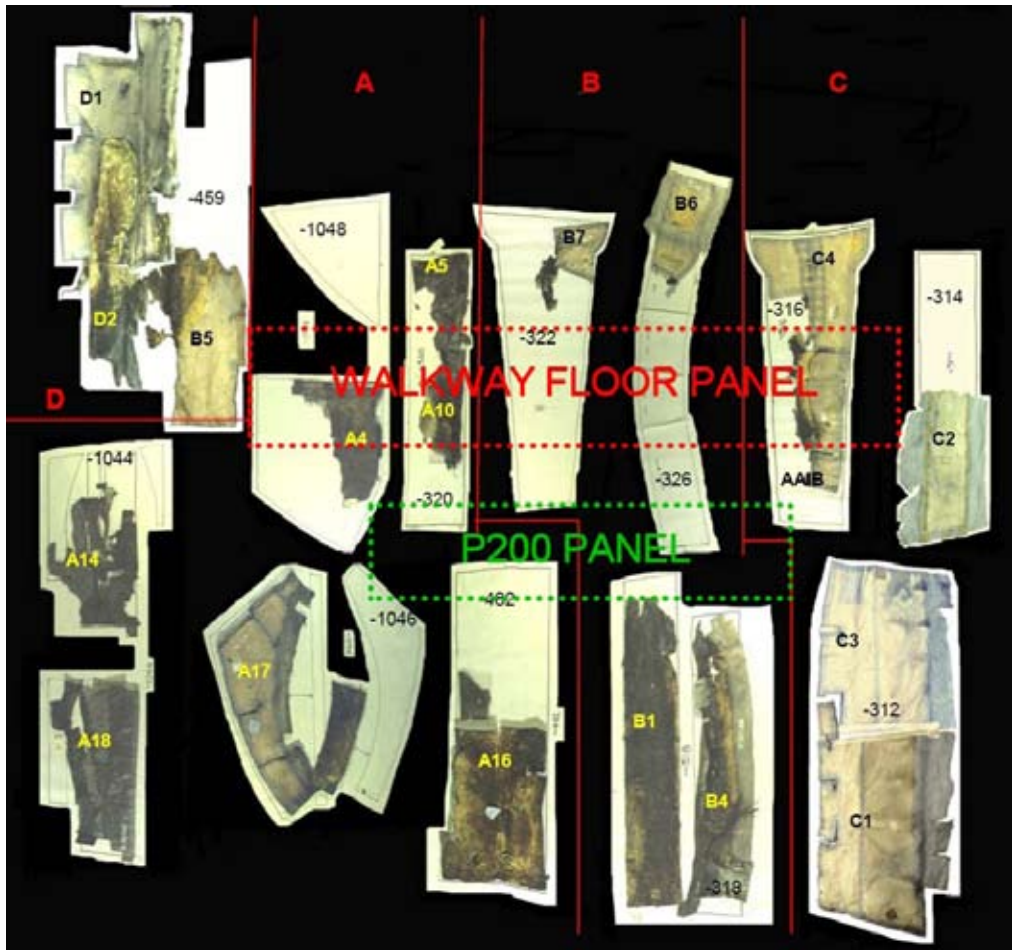

Figure 20

Composite photograph showing all the insulation blankets that were recovered and examined by the aircraft manufacturer. The blankets are laid out in sections A, B, C and D corresponding to Figure 19

The identifiable part numbers on the insulation blankets revealed that they were of ‘Original Equipment Manufacture’ (OEM) which meant that they were the type of blanket that would have been originally installed during manufacture of the aircraft. The insulation that was the most charred was in the area directly below and behind the P200 power panel. The known thermal properties of the insulation materials were used to determine the approximate temperature that sections of insulation material had been exposed to. A specimen was estimated to have reached a temperature of 250°C if its polymer liner had melted and its underlying fibreglass batting was still intact. A specimen was estimated to have reached a temperature greater than 500°C if the resin in the batting was completely burned leaving only glass fibres (see example photos in Figure 21).

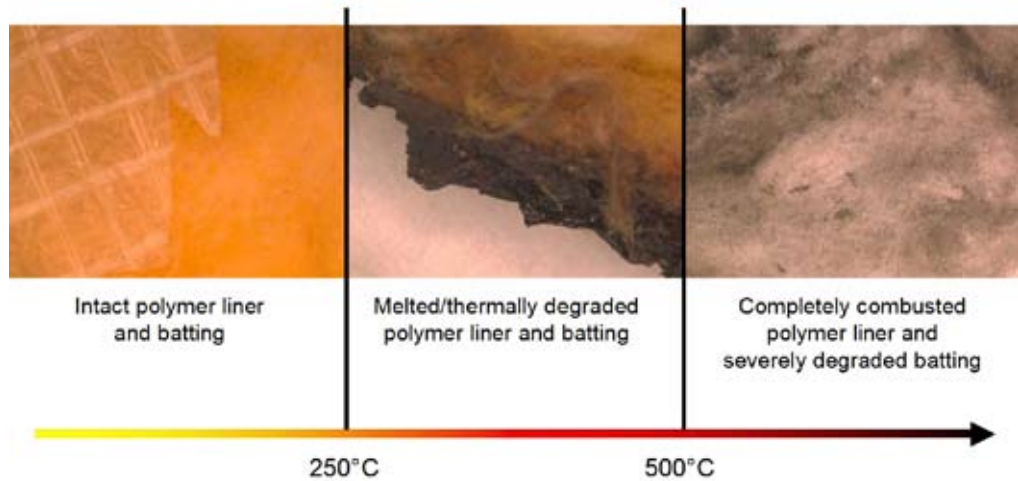

Figure 21

Estimated exposure temperature range as a function of insulation degradation

Once each section of insulation material was categorized a map was created to depict the estimated temperatures attained in relation to the location of the P200 power panel (see Figure 22). This map was produced using visual appearance only and is, at best, a rough estimate of the actual temperatures experienced during the event.

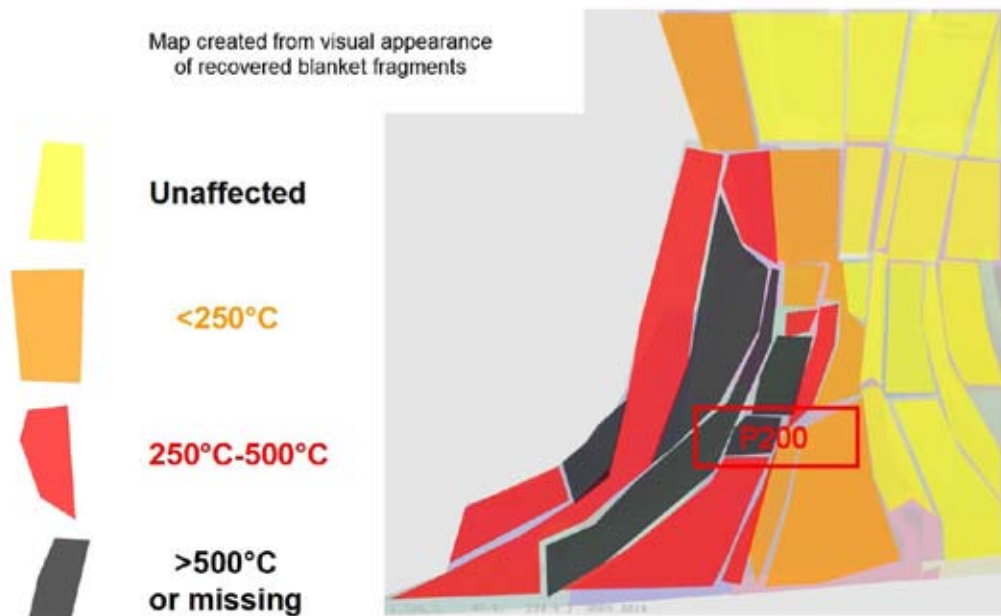

Figure 22

Top view of P200 panel showing estimated exposure temperature of surrounding insulation material

Drip and wipe samples from some of the insulation blankets were taken to establish if any contamination on the surface of the blankets might have contributed to the burning. A total of 17 samples were analysed using Infrared spectroscopy and one sample, an amber coloured droplet from an undamaged liner, contained corrosion inhibiting compound (CIC). Otherwise, other evidence of contamination was found that might have affected the insulation's flammability properties.

Samples of insulation from undamaged areas were cut out and then subjected to the Bunsen burner flammability certification test and the Cotton swab flame propagation test. The results of these tests are included in section 1.16.2.

Droplets of molten metal found on the P200 panel and on some blankets were also analysed by the aircraft manufacturer. The metals identified, using microprobe elemental analysis, included silver, copper and aluminium. These materials are all found inside a contactor. The melting temperatures of these materials are: aluminium 660°C; silver 961°C; and copper 1,084°C, although alloys of these materials can have higher melting temperatures.

1.12.5 P200 power panel examination

The P200 power panel, part number P-200-2002 and serial number TA-11993, was examined in situ and then removed from the aircraft for a detailed examination at the power panel manufacturer in the U.K. The front and rear of the panel are shown in Figures 23 and 24.

The RGCB was removed from the panel which revealed that its mating location (see Figure 25) had remains of one of the RGCBs plungers on its lower centre (B1 phase) mating point.

The RBTB was more difficult to remove than the RGCB, as significant parts of it had welded to its mating location (see Figure 25). The RBTB's plunger assemblies from the A1, B1 and C1 phases had all welded to the panel. There was a hole in the melamine backplane material between the B1 and C1 plungers.

1.12.6 Examination of Generator Control Units

No failures were found within the GCUs or BPCU that would have contributed to the accident. The NVM from the units was downloaded as was discussed in section 1.11.



Figure 23

Front of P200 power panel showing locations of RGCB, RBTB and GSR

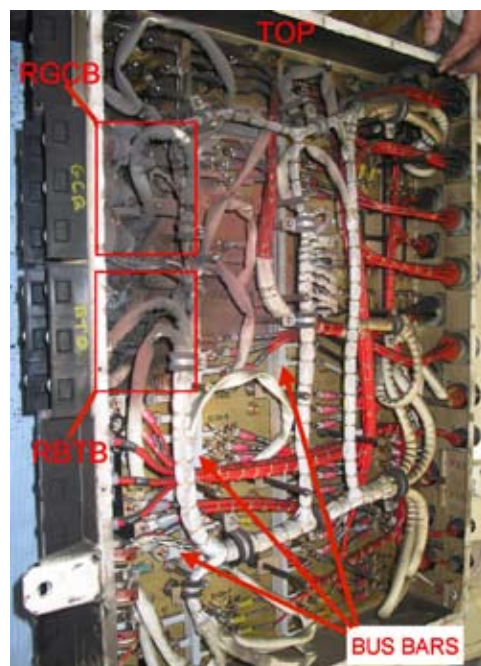

Figure 24

Rear of P200 power panel showing the bus bars, control wiring and the areas on the opposite side of the RGCB and RBTB

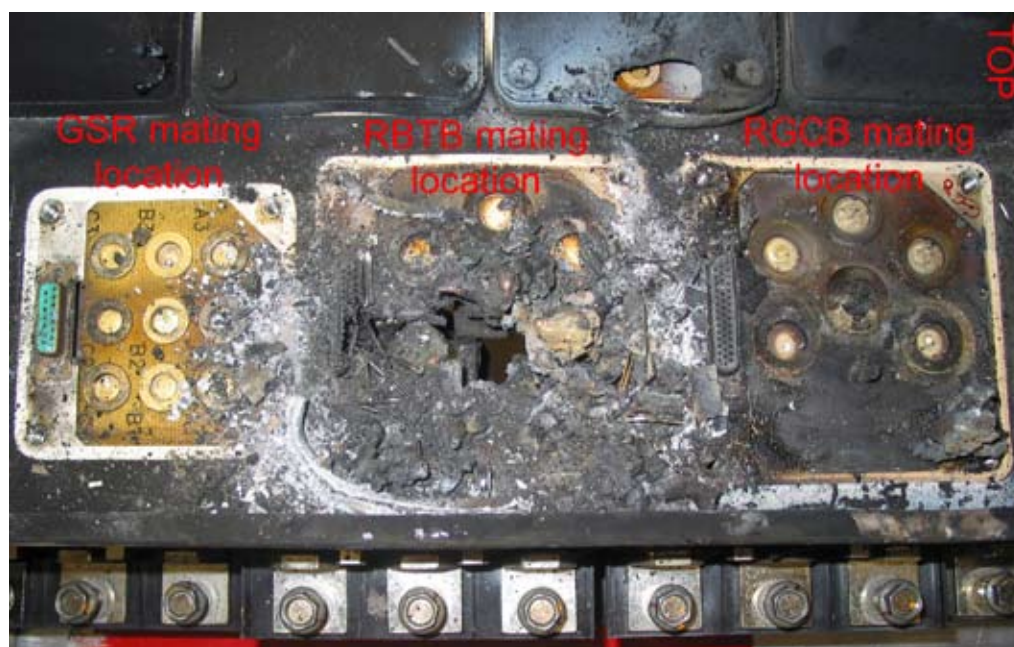

Figure 25

Close-up of front of P200 panel with GSR, RBTB and RGCB contactors removed

1.12.7 Examination of the failed contactors

The RGCB and RBTB contactors formed the focus of this accident investigation. The extent of the damage to the RBTB and RGCB can be seen in Figure 26, where they are compared to a new contactor. The damage to the GSR, located directly below the RBTB, appeared to have been caused by molten material dropping down from the contactors above and therefore was not the subject of detailed examination.

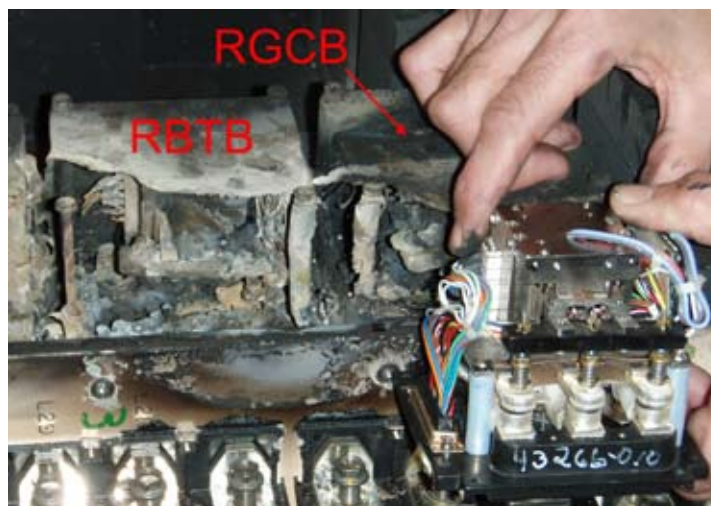

Figure 26

Comparison of RBTB and RGCB with a new contactor held in position
(note: arc chute has been removed from the new contactor)

After an initial examination at the power panel manufacturer's facility, the RGCB and RBTB were taken to the aircraft manufacturer's 'Equipment Quality Analysis' (EQA) laboratory for a detailed examination. They were later examined by ERA Technology in the UK to provide an additional independent analysis.

1.12.7.1 RGCB contactor examination

The RGCB was more intact than the RBTB and is shown in Figure 27. The movable contact support bar was found in the 'contactor closed' position and this was considered to be a reliable indication of the contactor's final state. The position of the auxiliary contacts could not be determined because heat had damaged the auxiliary contact actuation blocks which allowed all the contacts, in this case, to relax into an open state. All auxiliary contact blades were intact and accounted for.

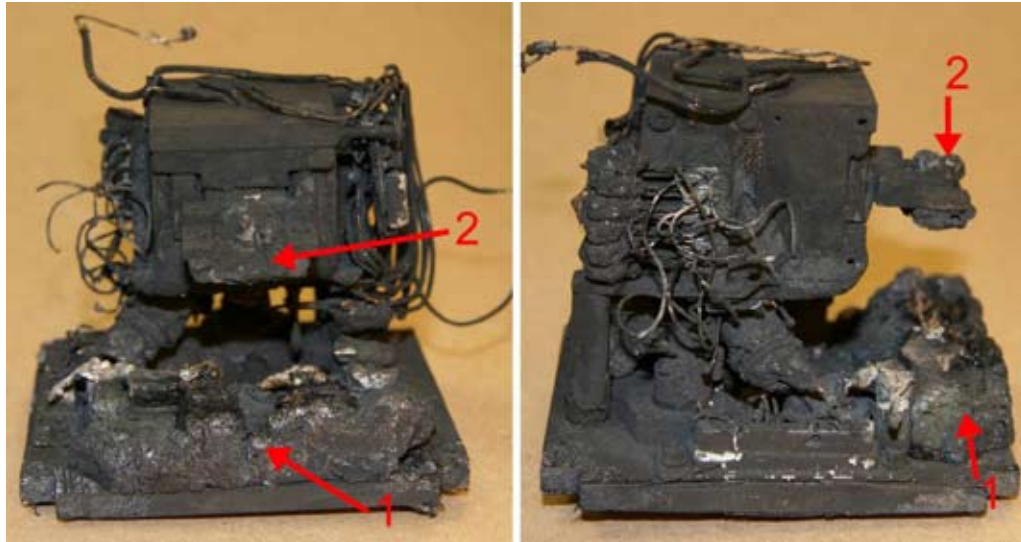

Figure 27

Damaged RGCB contactor: (1) stationary contact support block;
(2) movable contact support bar

The external base of the RGCB revealed evidence of a severe arc or short-circuit between the A1 and B1 phase plungers and between the C1 and B1 phase plungers (see Figure 28). The B1 phase plunger had melted or vaporised.

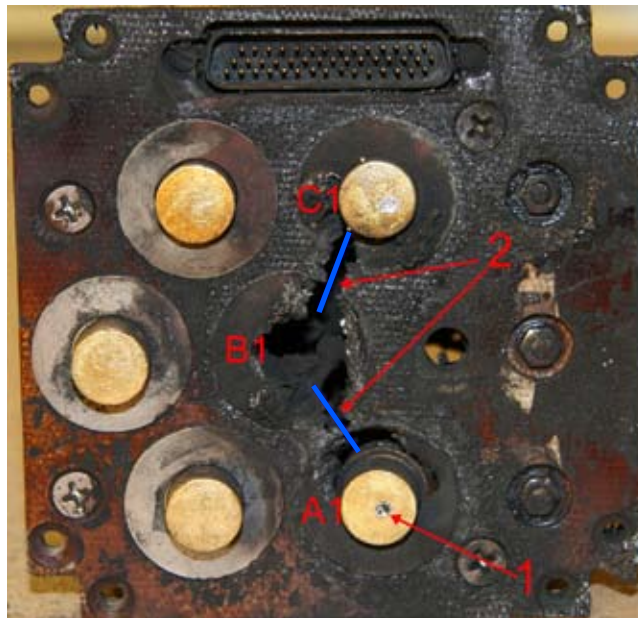

Figure 28

RGCB external base showing plungers: (1) pitting damage of the plunger due to arcing; (2) blue lines show where arcing or a short-circuit has burnt away the base plate material

The internal base plate of the RGCB revealed that part of stationary contact C was still intact (see item 1 in Figure 29), but it had a deep arc pit at its centre. Stationary contact A had melted. The Teflon arc chute had mostly melted or vaporised, but its two retaining screws were in place. The charred remains of the stationary contact support block were consistent with the melamine material used on the early contactors. Most of the silver pigtail foils had burnt away and three of the six plunger nuts had melted or vaporised; these were the three connected to the stationary contacts. The overall severity of the damage made it impossible to determine the initiating point of the failure, but the damage was consistent with a high degree of heat generated from multiple arcs and short-circuits. The most severe of these arcs were in the area of the main contacts and between the plungers and plunger nuts connected to the stationary contacts.

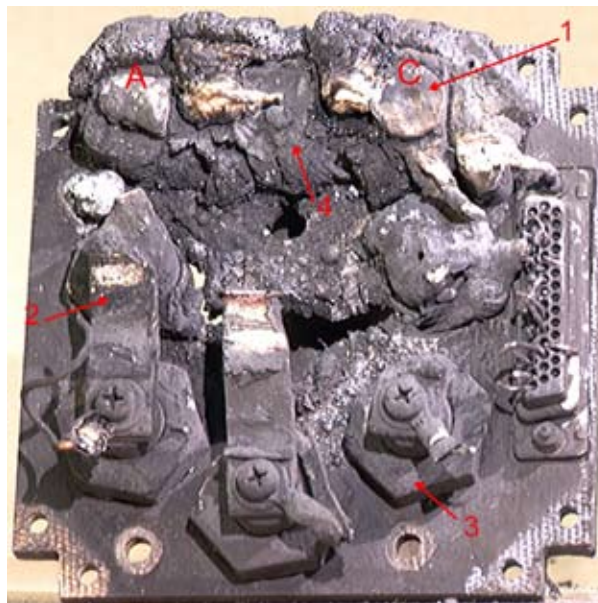

Figure 29

RGCB internal base: (1) sole remaining intact stationary main contact; (2) silver pigtail remains; (3) plunger nut; (4) stationary contact support block

1.12.7.2 RBTB contactor examination

The RBTB had suffered significantly more damage than the RGCB and therefore there were fewer remains to examine (see Figure 30). The RBTB's movable contact support bar was found in the 'contactor open' position. The position of the auxiliary contacts could not be determined because heat had damaged the auxiliary contact actuation blocks. All auxiliary contact blades were intact and accounted for.

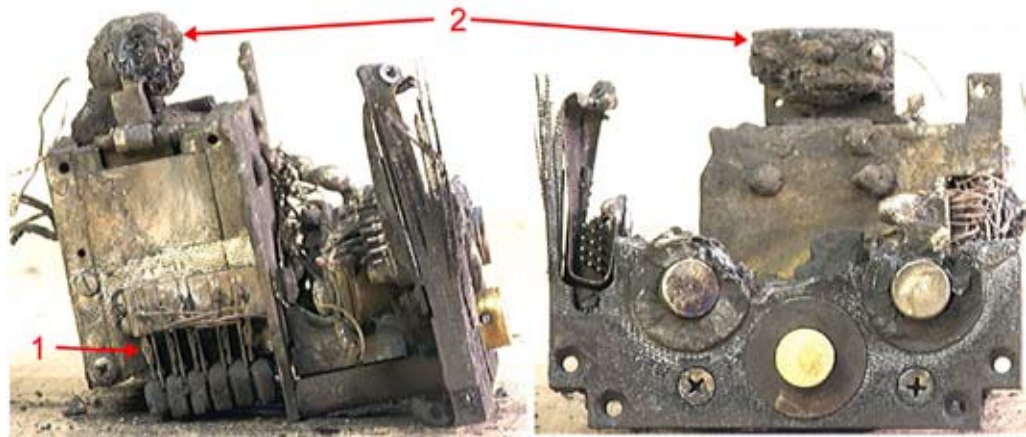

Figure 30

Damaged RBTB contactor: (1) auxiliary contact blades; (2) movable contact support bar

Only the three plungers connected to the movable contacts were still in place – the remains of the other three plungers were welded to the power panel. None of the stationary or movable contacts remained in the RBTB – all had melted or vaporised. Remains of the charred contact support block, consistent with melamine material, were visible. The arc chute had melted or vaporised, but its two retaining screws were found in place (see Figure 31). Most of the silver pigtail foils had burnt away.

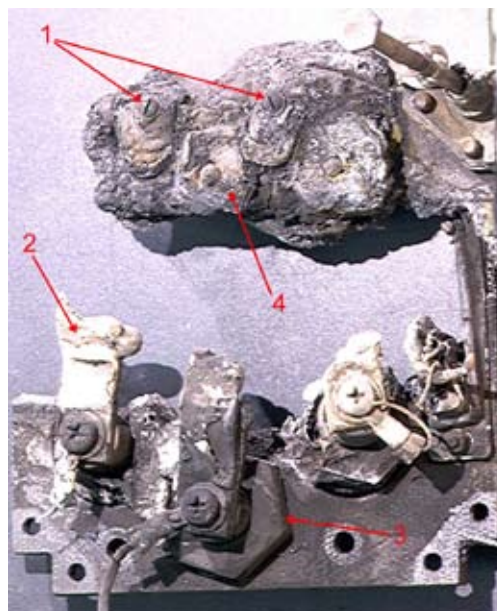

Figure 31

RBTB internal base: (1) arc chute retaining screws; (2) silver pigtail remains; (3) plunger nut; (4) stationary contact support block

As with the RGCB, the severity of the damage to the RBTB made it impossible to determine the initiating point of the failure. However, the damage was consistent with a high degree of heat generated from multiple arcs and short-circuits. As with the RGCB the arc damage to the RBTB was concentrated around the main contacts and around the plunger and nut assemblies connected to the stationary contacts.

1.13 Medical and pathological information

Not applicable.

1.14 Fire

1.14.1 Response by the airport fire service to the accident

The airport fire service was called by ATC to attend the aircraft at 1006 hrs and was in attendance at 1007 hrs, before the aircraft had taxied onto Stand 364. As this was a remote stand, with no air bridge available, the ground crew in attendance asked the fire service whether they should position steps or whether the passengers would be evacuating via the aircraft's emergency slides. They were told to position steps.

Once the aircraft was parked on stand fire-fighters equipped with breathing apparatus entered the aircraft via the MEC and via the steps placed at the aircraft to search for any sign of fire. The passengers and crew were then evacuated using the steps.

A thermal camera was used to search the cockpit, MEC and cabin for any fire. None was found although the MEC was filled with smoke and there was a strong smell of electrical burning and some smoke on the flight deck. As power had been removed from the aircraft, the forward cargo compartment had to be opened manually in order to check for signs of fire in the hold. Two cargo pallets were removed to facilitate the search, but again no fire was found. As the smoke slowly cleared in the MEC, obvious signs of fire damage could be seen in the area of the right P200 electrical panel.

The fire service liaised with engineering personnel present to confirm that they had identified the cause of the smoke and that there was no further danger. This was confirmed at 1136 hrs and the fire service was stood down.

1.14.2 Fire damage

Refer to sections 1.3 and 1.12.

1.15 Survival aspects

Not applicable.

1.16 Tests and research

1.16.1 Overview

The examination of the failed RGCB and RBTB did not provide sufficient evidence to determine the cause of the failures so additional tests and research were carried out. A number of high-cycle/ high-time contactors were removed from the Boeing 777 fleet and examined to see if any exhibited excessive deterioration or faults that might provide clues as to the cause of the failure events under investigation. The contactor manufacturer also carried out some endurance testing of an instrumented contactor mounted within a P200 panel, and carried out fault testing on the contactor. A historical review of manufacturing quality issues with the contactors was also carried out. In addition, all previous contactor failure incidents were examined and the aircraft manufacturer carried out instrumented ground tests on a Boeing 777 to measure transient currents during power transfers. Tests were also carried out on sections of the recovered insulation blanket material to determine how they compared to new insulation.

1.16.2 Tests of the insulation blanket material

Samples from the intact insulation blankets from around the fire-damaged area were taken and subjected to the vertical Bunsen burner flammability test (the FAR 25.853 required test) and the Cotton swab flame propagation test (a Boeing test).

Sixteen samples measuring 3 inches by 12 inches were cut from the insulation blankets and each sample was mounted vertically (lengthwise up) with the Bunsen burner flame beneath it (see Figure 32). Each sample was exposed to the flame for 12 seconds, after which its burn length, extinguishing time and drip extinguishing time were measured. The longest burn length of any sample tested was 5.4 inches, which was 2.6 inches less than the FAR of 8 inches. One sample had a flame which took 6 seconds to extinguish which was 9 seconds less than the 15 second requirement. The flame extinguished on all the other samples as soon as the burner was removed. There were either

no drips from the samples or the drips extinguished as soon as they were formed which was within the 5 second drip extinguishing time requirement. The full results of the tests are included in a table in Appendix E.



Figure 32

Vertical Bunsen burner flammability test setup

Twelve additional insulation blanket samples were cut and tested using the Cotton swab flame propagation test. This test is not required for certification but it is a Boeing test standard (BSS7357) and it is based on a procedure described in the FAA Fire Test Handbook. In this test, a cotton swab³² is soaked in isopropyl alcohol³³ and then ignited and placed on the flat surface or in the crease of a folded sample of insulation blanket material. The burn length is then measured and should not exceed 8 inches.

In the tests where the cotton swab was placed on a flat surface the burn length did not exceed 1 inch. However, when the swab was placed in the crease of a folded insulation sample the burn length extended further. Two samples had burn lengths of 9 inches and one sample had a burn length of 9.5 inches – all in excess of the 8 inch maximum requirement. The full results of the tests are included in a table in Appendix E. The aircraft manufacturer noted that the samples did not meet the size configuration of the BSS7357 test standard due to limitations of the available material, and the samples contained stitching thread and taped edges which would not normally be used as test samples and would increase burn length. The photographs in Figures 33 and 34 provide an idea of the fire spread during the cotton swab tests.

³² The cotton swab is taken from the end of a cotton bud stick (or Q-tip).

³³ Isopropyl alcohol burns at approximately 730°C.

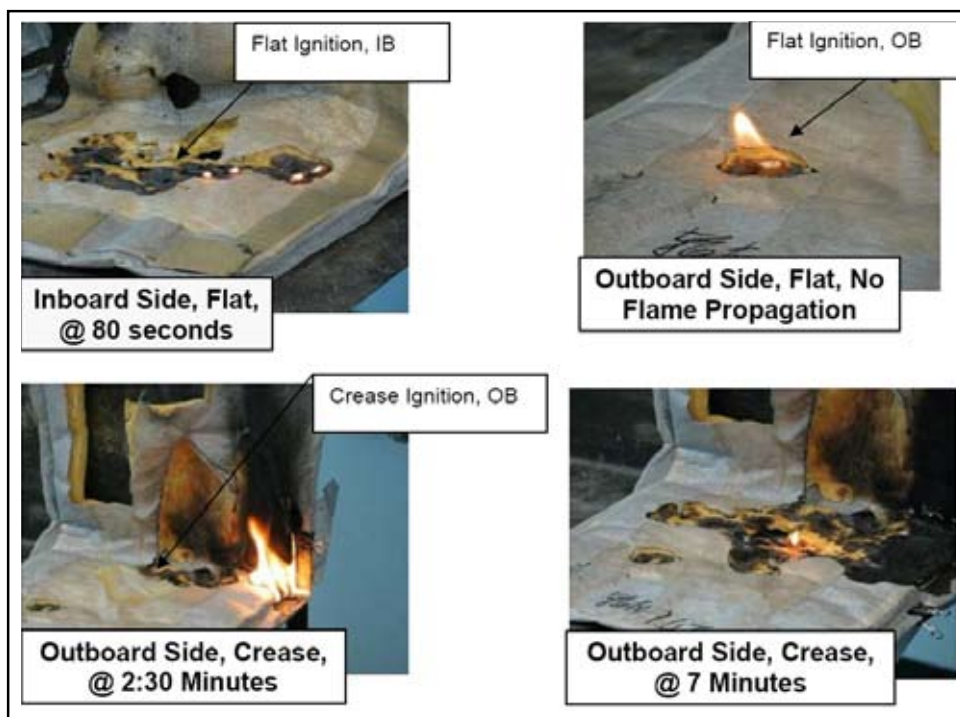

Figure 33

Cotton swab flame propagation test of sample 415W0110-314

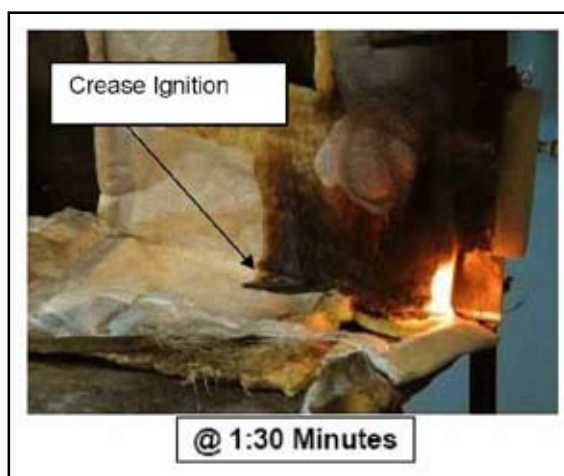

Figure 34

Cotton swab flame propagation test of sample 415W0110-459

The longest burn time of any sample was just over 7 minutes, but there was no time limitation as part of the test requirement. The burn areas from the cotton swab test were small compared to the extensive burn damage observed in the actual event, but in the actual event the insulation blankets were exposed to multiple molten metal droplets. The tests demonstrated that the insulation surrounding the burnt areas had flammability properties that were not significantly different from that of new insulation material.

1.16.3 Other Boeing 777 contactor and power panel failure incidents

There have been other incidents, both before and since the N786UA accident, which have resulted in severe contactor failure and/or severe power panel failure. The failures all involved ELMS 2 power panels. The N786UA accident was the first severe failure of a contactor on an ELMS 1 power panel. On aircraft fitted with ELMS 2 power panels there have been four events resulting in major damage to the panel or contactor, four events resulting in moderate damage, and five events resulting in minor damage. All ELMS 2 events involved either the APB or PEPC, apart from one event which involved the RGCB (moderate damage) and one event which involved the RBTB (major damage), although the RBTB was not deemed to be part of the cause in that event. None of the ELMS 2 failure events resulted in insulation blankets catching fire.

Since the N786UA accident, there have been four findings of overheated APBs on ELMS 1 power panels, but no reported failures of either an RGCB or RBTB. In July 2008 an incident was reported involving severe damage to the power feeder connections of a P300 panel in an aircraft fitted with ELMS 1.

1.16.3.1 Failures involving ELMS 2 power panels

In May 2006 a Boeing 777-200ER, registration PH-BQD, suffered major damage to its P200 power panel and PEPC during ground operations (see Figure 35). It occurred while primary external power was being applied to the aircraft. Mechanics noticed a burning smell and then removed the power. There was extensive damage to the P200 bus bars, including molten metal, and the PEPC was found welded to the panel. The movable contacts and the phase A and phase B pigtail foils inside the PEPC were destroyed. The aircraft manufacturer determined that the cause of the failure was due to a manufacturing defect of the bus to terminal lug connection; this became loose resulting in excessive heat build-up which damaged the bus bar and contactor.

In August 2006 a Boeing 777-300ER, registration A6-EBF, suffered damage to its P300 power panel and major damage to its APB contactor. The aircraft had landed and after engine shutdown the APU generator did not come online. The APU generator switch was cycled and the power came on. The aircraft was parked and the electrical power shut down. A few hours later a mechanic noticed a burning smell. When he applied electrical power to the aircraft he heard a loud bang. An inspection revealed a large burnt hole in the side of the



Figure 35

PEPC mating point from incident in May 2006 on aircraft PH-BQD

APB – see Figure 36. The aircraft manufacturer determined the direct cause to be an internal failure of the contactor, although the specific internal failure and root cause were not identified (see section 1.16.4 for further detail on the contactor examination).



Figure 36

Burnt APB contactor from incident in August 2006 on aircraft A6-EBF

In November 2006 a Boeing 777-300, registration 9V-SYK, suffered major damage to its P200 power panel and RBTB during ground operations. The aircraft was being powered by only the APU just prior to push back, when the crew noticed smoke and a burning smell. The APU was shut down and the passengers were disembarked. An investigation revealed that the P200 power panel had suffered overheating and arcing damage at the B1 bus input to the RBTB. The bus bar had melted at the B1 phase and the terminal block had overheating damage. The RBTB had welded to the panel with extensive damage around the plungers, although there was minimal internal contactor damage (see Figure 37). The aircraft manufacturer determined that the cause

of the failure was due to a loose terminal lug, due to a manufacturing defect or thermal cycling. A photo of the overheated terminal lug is shown in Figure 38. The terminal lugs on N786UA had not suffered from significant overheating.

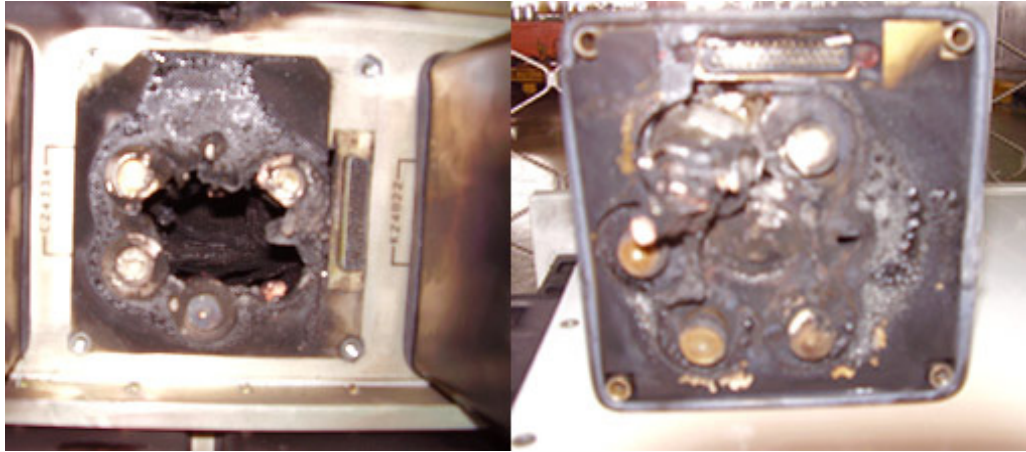

Figure 37

Damaged RBTB mating point (left) and RBTB (right) from incident in November 2006 on aircraft 9V-SYK



Figure 38

Overheated terminal lug on P200 panel from incident in November 2006 on aircraft 9V-SYK

The fourth incident which resulted in major damage occurred after the N786UA accident, in January 2008, on a Boeing 777-200ER, registration AP-BGK. In this incident ground power was applied via the primary external power connector, but the aircraft would not power up. An investigation revealed signs of arcing and overheat damage on the P200 backplane near one of the power feeder studs. The PEPC had not suffered significant damage

apart from overheat damage of the C1 plunger. The probable cause was determined to be a loose junction between the L11 panel terminal and the bus bar. This junction became hot, eventually causing the FR4 backplane material to degrade which resulted in phase-to-phase arcing across the backplane. The cause of the internal loose junction was not determined.

Of the four events involving moderate damage, the cause of three of them was attributed to the contactor. In December 2004 the APU electrical power would not come online on a Boeing 777-200ER, registration 9V-SVO. The APB and its backplane mating point were found to have overheating damage. The damage to the APB's arc chute is shown in Figure 39.

The source of heat in this contactor was attributed to a high resistance at the rivet junction of the phase B movable main contact. It was, however, not clear whether this was caused by a faulty rivet junction or whether heat build-up in the contactor caused the junction to loosen.

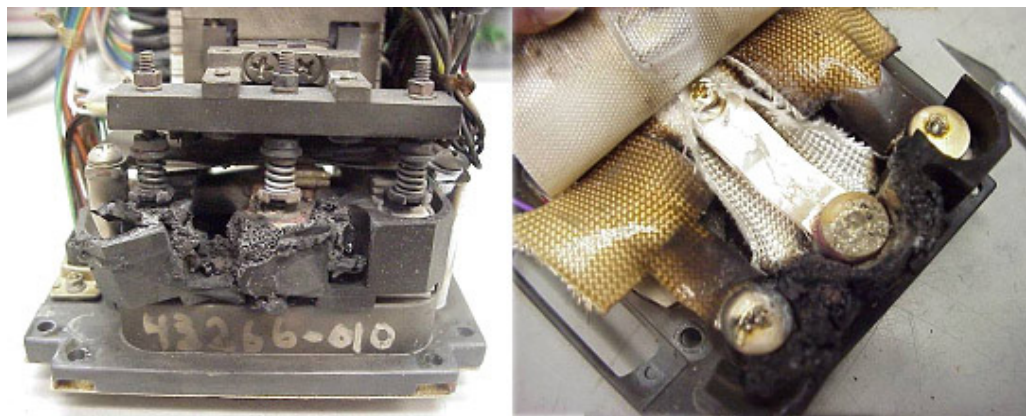

Figure 39

Overheating damage and arc damage of the Zytel arc chute from incident in December 2004 on aircraft 9V-SVO

Two of the other events involving moderate damage were to a PEPC (February 2005, F-GSQA) and to an APB (November 2006, 9V-SQN). The PEPC was lost in transit so could not be examined. The APB had evidence of significant overheating at the main contacts and this was attributed to a high resistance at the rivet junction of the phase A movable main contact. Again, it could not be determined if this was the direct cause or an effect.

The fourth event involving moderate damage occurred in January 2008 to aircraft A6-EBV. In this event the right IDG would not come online. An inspection

revealed overheating damage to the FR4 backplane material around the C1 phase mating point of the RGCB. The RGCB had also suffered significant heat damage to its C1 phase plunger (stationary contact side). It had heated sufficiently to reflow the braze material between the contact and plunger post, which would require a temperature in excess of 540°C. The spring within the C1 phase plunger had partially annealed and become 'heat set', reducing its set length, and thereby reducing the spring force applied to the plunger. The movable contact push rod for the C phase had conducted sufficient heat to displace the insert in the contact support bar, which reduced the contact over-travel. There was no damage to the other phases in the contactor. The root cause of the overheat in this contactor could not be determined.

The five ELMS 2 incidents involving minor contactor or panel damage were mostly due to minor over-heating events.

1.16.3.2 Failures involving ELMS 1 power panels

Prior to the N786UA accident there were no reported failures involving damage to either a contactor or power panel on an aircraft fitted with ELMS 1. Since the N786UA accident there have been four reports of minor damage to the APB on ELMS 1 panels. These were found during the inspections that were recommended following the N786UA accident. The damage to these APBs was all due to overheat, and was thought to be caused by operations on the ground in high ambient conditions with the APU generator as the only source of electrical power. An incident in July 2008 involving an ELMS 1 aircraft appeared to be related to a problem with the power feeder connections or internal bus bar to terminal lug joint, and not a contactor.

1.16.4 Examination of failed contactor from A6-EBF incident in August 2006

The failed APB contactor from the incident in August 2006 on aircraft A6-EBF underwent a detailed examination at the aircraft manufacturer's EQA laboratory. This contactor suffered significant arcing damage between the phase A and phase B main contacts – see Figure 40.

The phase A and phase B stationary and movable contacts had been completely vaporised by the arcing between them. There was also evidence of arcing between the plunger nuts; this probably occurred as a result of a rapid build-up of ionised arc plasma due to the short-circuiting between the A and B phases. This contactor revealed damage that could have been a precursor to the contactor failures on N786UA. However, no evidence was found that explained the cause of the initial arcing event.

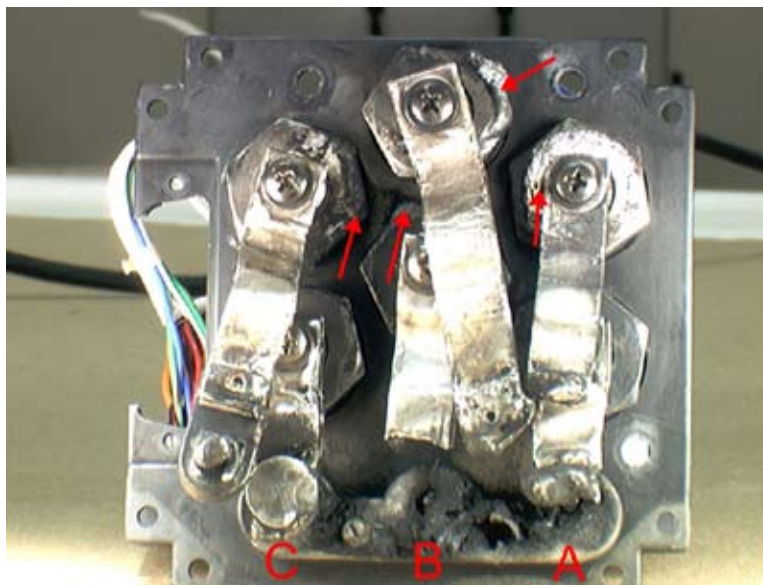

Figure 40

APB contactor base plate from aircraft A6-EBF. Severe arc tracking between phase A and B main contacts. Arrows indicate where arcing occurred across plunger cap nuts.

1.16.5 Examination of a sample of high-cycle/ high-time contactors from the fleet

A number of Boeing 777 operators were asked to supply high-time and high-cycle contactors from their fleet, so that they could be examined for possible early indications of failure. Four operators assisted with this investigation and a total of 32 operational contactors were removed from service. Three of the contactors submitted had either been repaired or reconditioned in the previous two years so these were not used to generalise about the condition of high-time/high-cycle contactors. The average hours of operation of the remaining 29 high-time/high-cycle contactors was 39,123 hours, ranging from 24,604 to 47,835 hours. The average number of aircraft cycles experienced by these contactors was 13,173 cycles, ranging from 5,654 to 22,000 cycles. All the 29 contactors were at least 9 years old from the date of manufacture. They consisted of 11 RBTBs, 7 APBs, 5 PEPCs, 2 RGCBs, 2 LGCBs, and 2 LBTBs.

All the contactors were tested in accordance with the Functional Test Procedure (FTP) that was used as acceptance testing for new production contactors. The contactors were then opened for an internal examination and photographs taken to document their condition. Summaries of the findings, in order of their frequency of occurrence, are listed below.

- 1) 12 contactors failed the operating time specification of the FTP or chattered on actuation using 15 VDC. This only occurred on the ELM 827-1 contactors which are magnetically held. The chatter is caused by the armature repeatedly opening and closing without getting to the fully open magnetically-latched position (the contacts themselves may or may not change state depending upon the amount of armature movement and degree of overtravel). When the operating voltage was raised the chatter did not occur, so it appeared to be caused by an increase in circuit resistance. This increase in resistance was in some cases caused by erosion of the 'throat cutter' switch contacts. The operating voltage on the aircraft would be closer to 28 VDC, so chatter would be less likely to occur. However, if chatter were to occur it could increase the duration of the arc, adding heat. Normal arc duration is about half a cycle so about 1 ms at 400 Hz. On the aircraft the GCU cuts off the coil command signal after 200 ms, so any contactor chatter would last for up to 200 ms, potentially increasing arc duration multiple times. The contactor manufacturer considered this insufficient time for any significant heat build-up to occur. The contactors which exhibited slow operating times were a few milliseconds beyond specification, but not slow enough for the aircraft system to detect a fault.
- 2) Six contactors failed the simultaneous operation specification of the FTP. The contactors are designed to ensure that all three main contacts make and break contact simultaneously within 3 ms. Six contactors were less than 1 ms out of tolerance on simultaneous contact operation. This was caused by different wear rates between main contacts, but the contactor manufacturer stated that this condition appeared not to affect the aircraft system.
- 3) Six contactors were found to have broken silver pigtail foils. In these contactors a single foil had separated from its attachment point to a movable main contact (see example in Figure 41). In the cases where the foil had broken free from the lower side of a movable contact, the foil had dropped down onto the insulation of the lower pigtail foil. Tests were carried out to examine the effects of a short-circuit via a single pigtail foil. The tests revealed that when shorted a portion of the pigtail foil vaporised instantly (acting like a fuse), which generated an air gap and prevented further damage.

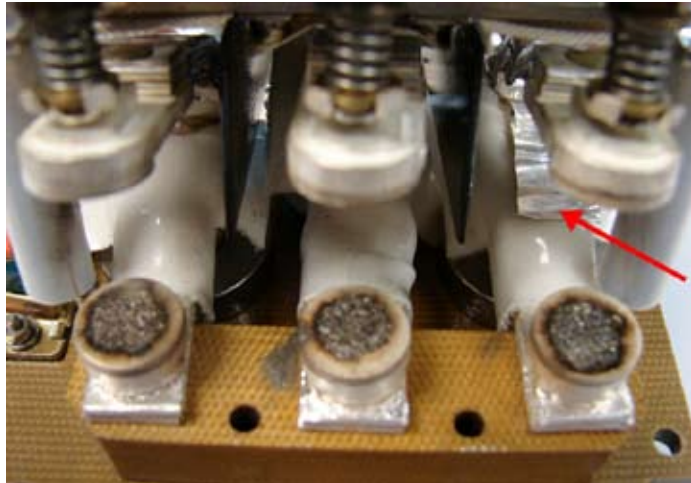

Figure 41

Example of a contactor with a broken pigtail foil. Red arrow points to a pigtail foil that has broken free from the upper movable contact and is resting on the insulation of the lower pigtail (movable contacts have been raised and arc chute removed to facilitate access)

- 4) Five contactors in the study exhibited evidence of over-heating. All five contactors were from the APB location. The evidence of over-heating included discolouration of the melamine plate that surrounds the plungers, discolouration of the insulation on the monitor wires, discolouration of the main contact support block and discolouration of the main contacts themselves. The cause of overheating was not determined, although the over-heating damage in these contactors had not reached an extent where it affected their operation.
- 5) Four of the contactors that were examined by the aircraft manufacturer's EQA lab were found to have debris deposits on the inside of the contactor cover (see example in Figure 42). The debris was analysed and was consistent with silver cadmium oxide, and was therefore probably arc debris.
- 6) Three contactors were found to have phase barriers with flaking of their epoxy coating. These older model contactors had aluminium phase barriers coated in an insulative epoxy. These barriers consisted of thin sheets mounted vertically between the pigtails of each phase. The epoxy flaking was found on the contactors that had experienced a degree of over-heating, and



Figure 42

Debris (probably arc debris) on the inside of the contactor cover of an RBTB
– this is adjacent to one of the main contacts

this heat had caused the epoxy to lose its adhesion. Since epoxy is insulative it does not pose a short-circuit risk but there is a possibility for loose flakes of epoxy to become embedded in various parts of the contactor. They could jam between auxiliary contact blades resulting in a false open circuit indication, or end up on the surface of the main contacts where they would melt and potentially increase the resistance between the contacts. Flakes of epoxy could also get stuck in the armature gap, reducing main contact pressure or preventing main contact closure. There was no evidence that these situations had occurred on the contactors examined. The failed contactors on N786UA had epoxy-coated aluminium phase barriers, although later model contactors had these replaced with sheets of glass fabric insulation.

- 7) Three contactors were found with significantly higher than expected contact erosion. These contactors were all from the RBTB location. The contact erosion pattern on these contactors had extended all the way to the edges – see Figure 43. For comparison, a photograph with more normal contact wear is shown in Figure 44. The contactors with high contact erosion also had significant dark arc ‘splatter’ deposits on the insides of the arc chutes. This ‘splatter’ was consistent with arcing occurring at the outer edges of the main contacts and raised concerns about ‘splatter’ crossing over from one phase to the next. The high contact erosion is indicative of high cycles and/or high current loads or possibly fault currents. Observations of contact wear on all 29 contactors revealed wide variations in the amount of wear

on contactors from the same aircraft positions with approximately the same number of aircraft hours and cycles. There was also variation in wear between phases. This could be due to load characteristic differences between aircraft and between phases.

The remaining over-travel gap (defined in section 1.6.7, page 17) is a measure of the depth of contact erosion. This gap is factory set to be between 0.018 and 0.032 inches. The high-time/high-cycle contactors averaged over-travel gaps of around 0.014 inches (meaning erosion of between 0.004 and 0.018 inches), although a minimum gap of 0.002 inches was measured on two contactors.

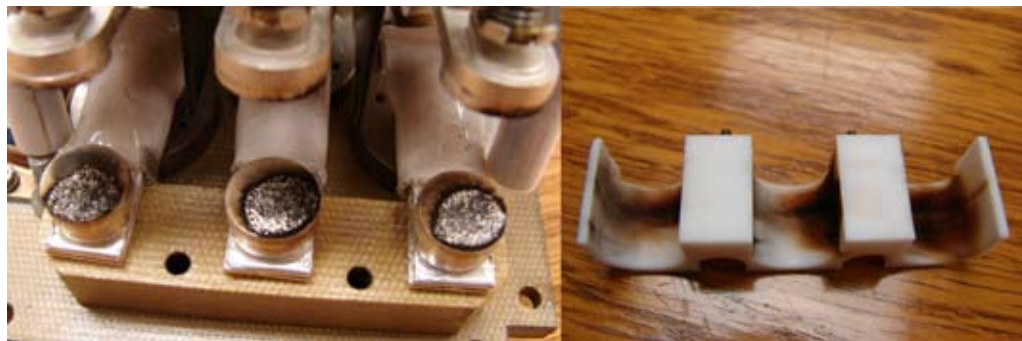

Figure 43

Example of a contactor with high main contact erosion (left) and dark arc chute deposits (right); this is an RBTB which has completed 45,700 flying hours and 14,500 flight cycles)



Figure 44

Example of normal contact wear (APB which has completed 25,000 flying hours and 22,000 flight cycles)

- 8) Two contactors were found to contain loose conductive material. One contactor contained a broken auxiliary contact blade. This contact blade showed evidence of a fatigue failure that may have been caused by over-adjustment during contactor assembly. The

blade is made from copper-aluminium alloy because it needs to act as both a conductor and a spring. The aluminium content provides the spring properties but also makes the material inherently brittle. The broken blade resulted in auxiliary contact switch 17-18 being permanently open circuit. The loose blade was found lodged in a fold of insulation, but it was long enough to have potentially caused a serious short circuit. However, the auxiliary contact blades on the failed N786UA contactors were all intact and accounted for. The second contactor containing loose conductive material was one of the APBs which had evidence of overheating. In this contactor one of the screws retaining the arc chute had come loose and was found lying inside the contactor cover. It probably came loose as a result of softening of the arc chute material due to heat exposure. The screw was long enough to have potentially caused a serious short circuit. However, both sets of arc chute screws on the failed N786UA contactors were found still in place.

- 9) One of the contactors had heat damage to its silicone insulation sleeve. This occurred in one of the APBs that had evidence of over-heating. One of the silicone insulation sleeves covering the B phase pigtail had started to burn – see Figure 45. This contactor also had white deposit material on the inside of the cover case which was determined to be a mixture of silicone oil and methacryamide aromatic acid. The silicone oil was probably from the burnt silicone sleeve but the source of the acid was not determined.
- 10) One contactor was found to have a movable contact that was rubbing against the edge of the arc chute, leaving silver rub marks on it.

Resistance measurements of the contactors, based on millivolt drop measurements, revealed that they all passed the 225 mV specification in existence at the time of manufacture, although four contactors failed the newly revised 175 mV specification that was put in place in February 2007 (see safety action in section 1.18.4.4, page 74). Measurements of millivolt drop at individual junctions inside the contactors revealed some that were slightly beyond specification; these were at contacts that had experienced high temperatures. It could not be determined whether these higher millivolt drop measurements were a result or a cause of the high heat.

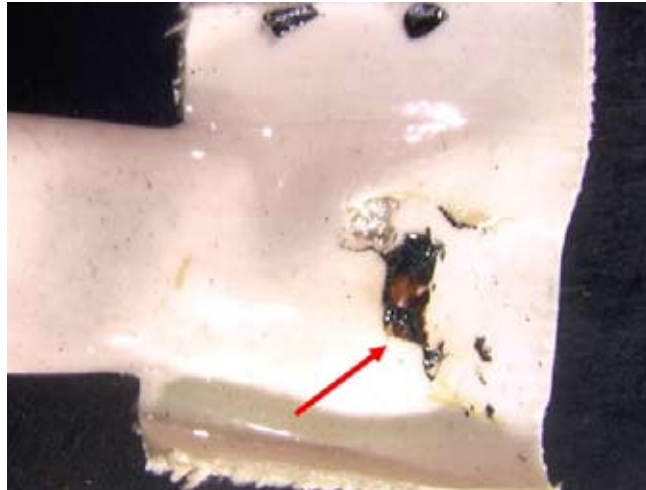

Figure 45

Burnt silicone insulation sleeve covering silver pigtail foil at B phase junction

Other conditions noticed during the study included burrs on some parts (which were probably formed during assembly and adjustment), small metallic particles stuck to the magnetic motor parts and main contacts out of alignment.

1.16.5.1 Examination of LBTB, LGCB and APB from N786UA

The LBTB, LGCB and APB from N786UA were examined as part of the high-time/ high-cycle contactor study. The LBTB passed all the FTP tests, and although over-travel measurements on both the B and C phase contacts were below new limits, this was considered to be consistent with normal contact wear. The LGCB experienced contactor chatter at 15 VDC but this cleared at a higher voltage. The over-travel measurement on the LGCB's A phase contacts was below new limits, but this was considered normal wear. The APB exhibited evidence of having experienced high temperatures. The B and C phase main contacts were discoloured from heat and there was some heat discolouration of the insulation from a sensor wire. The APB also experienced contactor chatter which cleared at a higher voltage. All three phases had over-travel measurements below new limits but this was considered normal wear. Two voltage drop measurements on phase A were slightly outside limits, indicating higher than normal resistance at these two junctions.

1.16.5.2 Examination by ERA of a high-time/ high-cycle contactor

When ERA Technology carried out an examination of the failed RBTB and RGCB from N786UA they also examined one of the in-service contactors from the high-time/ high-cycle study. This contactor (s/n CL-83606) was

from the RBTB position on a Boeing 777 that had accumulated 42,969 hours and 6,550 cycles. It was also one of the contactors with high main contact wear and a severed pigtail foil.

ERA used a Scanning Electron Microscope (SEM) and Energy Dispersive X-ray (EDX) analysis to examine the main contact surfaces of contactor CL-83606. The examination revealed the presence of some contaminants on the surface of the silver cadmium oxide main contact surface. These included organic material (i.e. carbon content) and magnesium, aluminium and silicon which were present as oxides and would be electrically insulating. There were also areas where the silver cadmium oxide had been reduced to silver cadmium alloy probably as a result of an interaction with organic contamination. Contamination by insulating materials on the contact surface can increase contact resistance which increases temperature. However, the contactor manufacturer pointed out that this contactor passed the FTP test and therefore the main contact resistance (based on millivolt drop) was within limits.

ERA also noticed that there was some contamination on the main contact support block between main contact phase A and B, which had the appearance of arc spray deposits. This was on the top surface of the contact support block in an area that was not covered by the arc chute – see Figure 46. The arc chute prevents arc spray from being deposited on most of the space between contacts but leaves 2 mm at the edge of each contact within line of sight of each other, and this is where the deposited material had occurred. The arc spray deposit was analysed using SEM/EDX which revealed that its composition was variable, but its major constituent was aluminium alloy and only a minor constituent was silver cadmium.

The only materials inside the contactor that use aluminium are the cover, the epoxy coated phase barriers, and the four spacer posts that hold the actuator assembly above the base. There was no evidence that any of these were worn or had been damaged, so the likely origin of the aluminium deposits was contamination during the assembly process.

1.16.6 Endurance test of an instrumented contactor

The contactor manufacturer carried out an endurance test of a new production contactor to determine if it would be damaged under typical high level current loads in a simulated aircraft environment. The contactor was installed in the RBTB position of a P200 panel and the panel was mounted in an environmental chamber. The contactor was loaded to between 345 and 354 Amps at 115 V for a continuous period of 45 minutes³⁴ and then it was cycled open and closed

³⁴ 45 minutes was chosen as the time period because lab experience showed that a temperature plateau occurred after about 45 minutes.

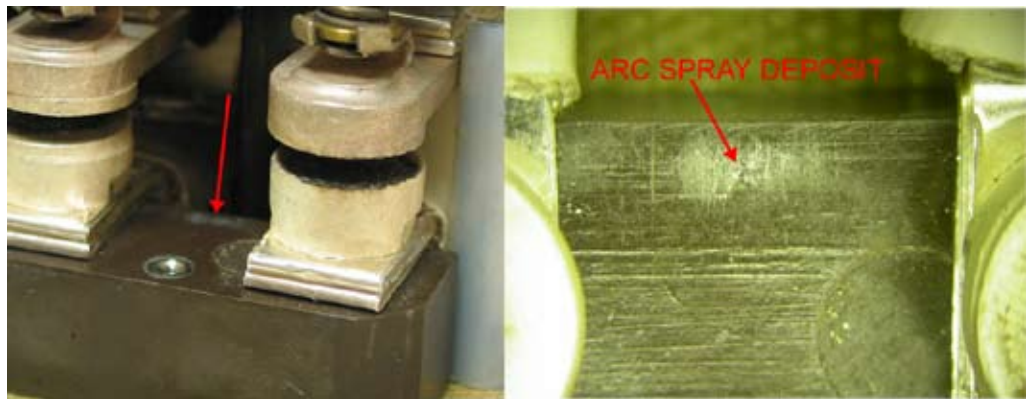

Figure 46

Arc spray deposit on main contact support block indicated by red arrow (left); close-up of arc spray deposit (right)

for 5,000 cycles. This was then followed by a further 45 minutes of loading and 5,000 additional cycles, until a total of 50,000 cycles had been completed. The first 25,000 cycles were carried out in a chamber temperature of 60°C and at a pressure altitude of 8,000 feet. The remaining 25,000 cycles were carried out at ambient temperature and pressure. After every 5,000 cycles the contactor was removed from the panel for a visual internal examination and some tests. A complete FTP functional test was carried out at 25,000 cycles and 50,000 cycles.

The contactor was instrumented with temperature sensors at selected junctions inside the contactor and with a miss detector which would sense if the contactor had been commanded to open or close but had not changed state.

The contactor used in this test was a new production contactor manufactured in September 2007. This differed from the failed N786UA contactors in the following aspects:

- The base plate and contact support block were made of moulded Dielectrite instead of melamine.
- The phase barriers consisted of glass fabric sheets instead of epoxy coated aluminium.
- The arc chute material was Ryton instead of Teflon.
- The arc chute screws were coated in Loctite.

These changes were all improvements made since the failed N786UA contactors were manufactured in February 1995 but the main contacts, pigtails, plunger assembly and armature were unchanged.

The full report on all the findings from the endurance test is included in Appendix F. A summary of important findings is included here. The highest internal temperatures were obtained during the 45 minute continuous loading and these did not vary for the first 25,000 cycles. The hottest part of the contactor was the stationary B phase main contact which reached a temperature of 225°C at the end of a 45 minute period. The temperature of the other contacts was between 175°C and 220°C. The temperatures during the second set of 25,000 cycles were approximately 40°C lower due to the lower (ambient) chamber temperature. The contactor in the RGCB location, which was not under test, reached an internal temperature of 235°C at the A phase contact.

Most of the main contact erosion occurred during the first 15,000 cycles where the remaining wear allowance (based on over-travel measurements) reduced from 0.023 inches to 0.020 inches. Less than 0.001 inches of additional wear occurred during the subsequent 35,000 cycles.

After 10,000 cycles the oscilloscope monitoring contactor cycling showed some contactor chatter following an open command. This persisted intermittently until, after 25,000 cycles, the auxiliary contact commanding the trip voltage (throat cutter switch) was manually adjusted which eliminated the problem. During the 25,000 cycle inspection a small solder ball, approximately 4 mm in diameter, was found in the contactor cover. The ball had a flat spot where it had probably fallen against a part and adhered. It probably originated from some wire soldering on the printed circuit board.

At the 45,000 cycles inspection a piece of brass shim material, approximately 8 x 4 x 0.1 mm in size, was found inside the contactor cover. The piece originated from a shim that is used in the armature gap to reduce magnetic force. The shim breakage was attributed to fatigue due to it not having been formed at 90°. The armature's magnetic properties were not affected by the shim breakage, but it posed a potential short circuit hazard.

Towards the end of the test the B phase contact mating point had migrated to near the front edge of the contact causing material splatter to create a ragged edge on the contact, but the temperature was not increasing. The contactor continued to operate without failure up to the 50,000 cycle test limit. The condition of the main contacts at the end of this test is shown in Figure 47.

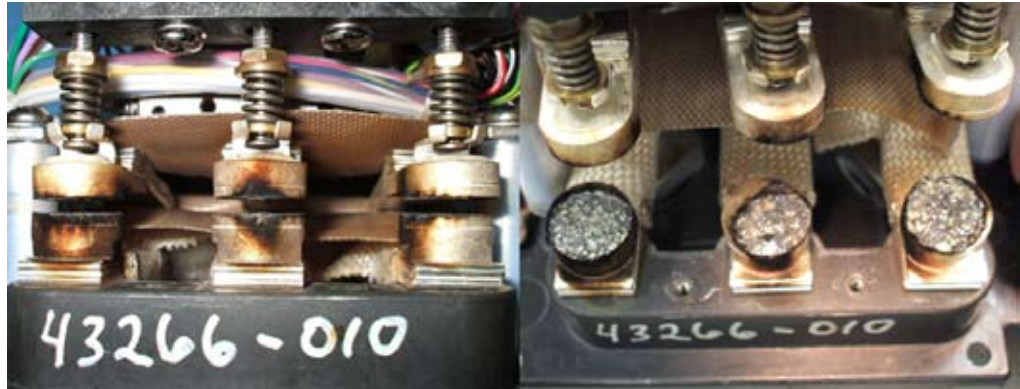

Figure 47

Condition of main contacts following 50,000 cycle endurance test

Resistance measurements, based on millivolt drop, taken at the different stages during the test revealed gradual increases in resistance. At the end of the 50,000 cycles the millivolt drop across the B phase main contacts was 187 mV against the specification maximum of 175 mV. However, the contactor passed all the other requirements of the FTP test, including the dielectric withstand voltage test which would indicate if any arc debris was starting to create any conductive paths across insulating material.

1.16.7 Fault testing of a contactor

At the completion of the contactor endurance test, the contactor which had completed 50,000 cycles was subjected to overload and fault currents to determine if any failures would occur. No reconditioning of the contactor was carried out prior to the fault testing. The contactor was subjected to four cycles at each of the following overload and fault conditions, with a 5 minute cool-down between fault applications:

- 400 ± 20 Amps for 15 minutes
- 450 ± 22.5 Amps for 5 minutes
- 550 ± 27.5 Amps for 90 seconds
- 875 ± 40 Amps (895 actual) for 10 seconds
- 1500+ Amps (1,708 actual) for 1.3 seconds, repeated twice

The above conditions were determined based on the aircraft manufacturer's specified potential fault currents before system protections are activated.

The contactor withstood all the applications of overload and fault current without failing. The internal contactor temperatures did not exceed those measured during the endurance test. There was no damage to the contactor or welding of contacts. The unit passed the dielectric withstand voltage test and insulation resistance tests. The millivolt drop measurement across the B phase main contacts had increased to 216 mV (limit 175mV), while the millivolt drop across the A and C phases remained within limits.

1.16.8 Examination of previous contactor manufacturing quality issues

The N786UA contactors which failed were manufactured in 1995 so the contactor manufacturer was asked to examine its manufacturing records for the period between 1994 and 1996. Any quality issues that arose during this period should have been addressed by an Engineering Change or a Manufacturing Process Change, so the records for these changes were examined. Sample repair station records for the period were also examined. The following two Engineering Changes were found that resulted from quality issues:

In 1995 the nut on the stationary contacts was changed from brass to stainless steel so that more torque could be applied (ECN³⁵ 27517). This was changed because nuts were found to loosen due to material shrinkage when under compression.

Also in 1995 an insulation sheet was added behind the printed circuit board because of a dielectric breakdown between the circuit board and actuator frame when tested at 1,050 V (ECN 28920).

The examination of repair records revealed 67 records for contactors manufactured between 1994 and 1996. Of these, 55 had functional discrepancies when tested against the FTP. Five contactors had damage from over-heating. Three contactors had damage through improper handling. Two contactors had loose internal fasteners. Five contactors were found to have loose material free inside the cover. Three of these were broken auxiliary contact blades, one was epoxy flakes and the fifth was a screw from the auxiliary contact operator assembly. This screw was approximately 6 mm long. Since May 2005 these screws are assembled with Loctite. The N786UA failed contactors had all auxiliary operator assembly screws in place.

There has been one reported case of a welded main contact. In June 2007 a contactor from the RBTB position was returned to the contactor manufacturer because of a failure message indicating that the RBTB was not in its commanded

³⁵ ECN is the Engineering Change Number.

position. An examination revealed that the phase C main contacts were tack welded, preventing the motor from opening the main contacts. The weld was broken by applying manual force and then the contactor was tested in accordance with the FTP; it passed all the tests and the contact force settings were normal. The cause of the contact welding was not established.

1.16.9 Power transfer ground test results

Between 3 and 4 April 2008 the aircraft manufacturer carried out a ground test using a new production Boeing 777 (WD848) to examine the effects of ground power transfers. The testing was done in two configurations. The first used an instrumented contactor installed in the RBTB position and the second used two contactors with service experience installed in the RBTB and RGCB positions. The test goals were to measure and evaluate current transients during power transfers, measure and evaluate coil voltage available at the contactor, and to evaluate the impact of contactor age on power transfers.

The test results showed that no current transients above specification limits occurred during any of the power transfers. During some power transfers, when a NBPT was expected, a break power transfer occurred instead, but this was considered acceptable. The tests with the used contactors revealed that the contactors remained in parallel for longer during an NBPT at power up when compared to a new contactor. However, during an NBPT at power shutdown the used contactors remained in parallel for a shorter period compared to a new contactor. The measurements of coil voltage available at the contactor were within the specification of 28 ± 3 VDC.

1.16.10 Contactor insulating material properties

The primary insulating materials used in the contactors have changed over the years and are summarised in the table below:

	Original	early 1995	early 1997	early 2000	early 2007	Planned end 2008
Contactor Base	Melamine	Melamine	Dielectrite	Dielectrite	Dielectrite	Dielectrite
Contact Support Block	Melamine	Ryton	Dielectrite	Dielectrite	Dielectrite	Dielectrite
Arc Chute	Teflon	Teflon	Teflon	Zytel FR-10	Ryton	Dielectrite

Table 1

History of contactor material changes (contactor manufacturer was not able to provide exact dates)

The thermal properties and dielectric strength properties of these materials are presented below. Some of these properties were determined by tests carried out by the contactor manufacturer and other properties were taken from material specification sheets. The dielectric strength of a material is a measure of its strength as an insulator. The dielectric strength is defined as the maximum voltage required to produce a dielectric breakdown through the material, and is expressed in Volts per unit thickness (usually V/mil, volts per thousandth inch). The higher the dielectric strength of a material, the better its quality is as an insulator. As a material starts to degrade due to heat its dielectric strength can be affected.

The melamine material (Glass 60, G9) is a melamine resin containing glass fabric material. It has a dielectric strength of 450 V/mil. Melamine is a thermoset plastic³⁶ and therefore has no melting temperature. Tests of the melamine material showed that it started to discolour at 200°C. It turned black at 340°C and the internal resins started to bubble at 370°C. At 400°C the resins started to char and flake away. Material which had been exposed to 400°C passed dielectric testing at 1,800 V with no breakdown or arc over, although there was a current leakage of 150 microamps³⁷. Material hardness was not tested although there is evidence to indicate that Melamine starts to soften at 300°C.

Dielectrite (44-10Hg, Type MA160) is also a thermoset plastic and therefore has no melting temperature. It has a dielectric strength of 300 V/mil. Tests showed that it changed from black to brown at 400°C. At 510°C the material turned white as the plastic resins began to break down. At 565°C the material turned completely white and began to flake off. At this temperature the material passed dielectric testing at 1,800 V with no breakdown or arc over.

Zytel (70G33L NC010 Nylon 66, 33% glass fibre) is a thermoplastic with a dielectric strength of 410 V/mil. It was tested and started to melt at 305°C. The material started to char at 345°C, and at 370°C the material had burned mostly to ash. The dielectric test at 1,800 V was passed with material that had been exposed to 345°C, but dielectric breakdown occurred after a few seconds at 1,800 V to material that had been exposed to 370°C.

Teflon³⁸ (PTFE 8) has an initial melting temperature of $342^{\circ} \pm 10^{\circ}\text{C}$ and a dielectric strength of 285 V/mil. It was not tested.

36 Thermoset plastics burn but do not melt, unlike thermoplastics which melt above a certain temperature.

37 This testing was done with a spacing of 0.25 inches between dielectric probes, unlike dielectric rating tests.

38 Teflon is the DuPont brand name for the thermoplastic PolyTetraFluoroEthylene (PTFE).

Ryton (R4) is a 40% glass fibre reinforced polyphenylene sulphide (PPS) plastic material which has a melting temperature of 282°C and a dielectric strength of 540 V/mil. It was not tested.

1.17 Organisational and management information

There were no issues with the organisation or the management of the companies involved that were relevant to the cause of the accident.

1.18 Additional information

1.18.1 Flight crew checklists

The relevant flight crew checklists for the failure event were the ‘ELEC AC BUS L (R)’ checklist, the ‘SMOKE/FUMES/FIRE ELEC’ checklist and the ‘EQUIP COOLING OVRD’ checklist.

The ‘ELEC AC BUS L (R)’ checklist is for the condition of an unpowered AC bus. The first action is to cycle the generator control switch from the affected side, OFF and then ON, and attempt only one reset. If the ‘ELEC AC BUS L (R)’ message remains displayed the next action is to start the APU. If after starting the APU, the message is still displayed the next action is to select the bus tie switch from the affected side, from isolation to auto, and attempt only one reset.

The ‘SMOKE/FUMES/FIRE ELEC’ checklist initial actions are: don oxygen mask and regulators (if required), establish crew communications, turn gasper switch off (which removes fan as a possible source of smoke/fumes), and turn recirculation fans off. If the source of smoke can be determined, power should be removed from the affected electrical equipment by a switch or circuit breaker. If the smoke persists or the source is unknown then the checklist instructs for various cabin and in-flight entertainment systems to be turned off, and to accomplish a landing at the nearest suitable airport. It also directs the crew to the ‘SMOKE/FUME/ODOR REMOVL’ checklist.

The ‘EQUIP COOLING OVRD’ checklist covers the condition that the equipment cooling system has gone into override mode. The first instruction is to wait for two minutes to allow time for any smoke in the system to clear. The next action is to cycle the Equipment Cooling Switch OFF and then to AUTO. If the ‘EQUIP COOLING OVRD’ message remains displayed, then the crew are to note that *‘After 30 minutes of operation at low altitude and low cabin differential pressure, electronic equipment and displays may fail.’*

1.18.2 Consequences of the N786UA failure condition occurring in flight

The aircraft manufacturer carried out an assessment of the potential failure conditions and consequences in the event that the N786UA contactor failures had occurred in flight. Power transfers in flight do not involve NBPTs which may reduce the risk of contactor failures of the type seen in the N786UA accident, but this is not known for certain. The loss of the Right Main AC Bus would not have affected safe flight as there was sufficient redundancy within the electrical system. The effects of the fire in the MEC which affected aircraft structure, wiring, air ducts and control cables are addressed below.

The heat damage to some structure had reduced its strength by 34% but the aircraft manufacturer assessed that all the affected structural elements would have sustained in-flight pressure loads and 'get-home' limit loads, had the heat damage occurred in flight. If the damage had been worse, the structure was designed to withstand decompression loads resulting from an opening of 1.86 m² in the fuselage skin and permit continued safe flight and landing.

Two air ducts behind the P200 panel had suffered heat damage. If these ducts had been compromised, there would have been no additional hazard from added airflow to the fire because the equipment cooling system had gone into override mode. The control cables in the fire-affected area were high strength steel and capable of surviving high temperatures. Had these cables failed in flight, the backup stabilizer control system would have been lost (but the primary electric system would have still functioned), and the ability to release the right main gear brakes would have been lost which could have resulted in potential controllability issues after landing.

The wiring from the P205 panel had suffered some heat and fire damage and this could have been more severe. Failures in the P205 panel wiring could result in the loss of all Warning Electronic Units, activation of false alarms and the loss of both backup generators. Of the potential false alarms, the most serious would be a 'FIRE ENG L' and a 'FIRE ENG R' caption on the EICAS, accompanied by the associated aural warnings. Assuming the flight crew did not react to these warnings by shutting down both engines, then none of the P205 wiring failures would directly prevent continued safe flight and landing.

1.18.3 Probability of the N786UA failure condition occurring in flight

The aircraft manufacturer carried out an analysis to determine the probability of a serious contactor failure occurring in flight. The analysis assumed that a switching operation was required to initiate a serious contactor failure. For the

RGCB or RBTB to switch in normal flight a failure needs to occur that requires a power transfer. The most likely failure to trigger a power transfer in flight would be an engine failure or an IDG failure. The probability of either occurring was determined to be 1.03×10^{-3} per flight cycle. The probability of a contactor failure occurring after a power transfer was estimated to be 1.3×10^{-6} per flight cycle – this figure was based on the number of contactor failures that had occurred to date. Therefore, the overall probability of a contactor failure occurring in flight was estimated to be 1.34×10^{-9} per flight cycle³⁹. In terms of flight hours, this equates to 3×10^{-10} per flight hour (the manufacturer assumes an average flight to last 4.5 hours). Certification rules require that the probability of a catastrophic failure be less than 1×10^{-9} per flight hour. Since the estimated probability of a contactor failure occurring in flight was less than this, the aircraft manufacturer determined that a contactor failure in flight was not a ‘safety issue’. However, the probability of a contactor failure occurring on the ground was significantly higher, because power transfers occur routinely at the start and end of every flight. If a contactor failure on the ground causes a fire there is a chance that the flight crew will order an evacuation; emergency evacuations using slides can result in injury to passengers. Therefore, the aircraft manufacturer’s Safety Review Board determined that contactor failure was a ‘*Personal Safety Issue based on the potential for emergency evacuation in the event of occurrence on the ground...*’.

1.18.4 Safety action taken

Throughout the duration of the N786UA accident investigation the aircraft manufacturer, contactor manufacturer and power panel manufacturer were pro-active in trying to determine the root cause of the problems and also developed safety measures to try and prevent recurrence. A summary of safety action that has been taken is presented here.

1.18.4.1 Safety action taken by the aircraft manufacturer

Before the N786UA accident the aircraft manufacturer was already involved in trying to determine the cause of the previous contactor and power panel failures. In response to those investigations and on-going investigations after the N786UA accident, the aircraft manufacturer issued the following ‘Multi Operator Messages’ (MOMs):

MOM 1-257662432-2, dated 1 December 2006, informed operators of the panel and contactor failures to date and requested that they monitor for particular maintenance messages.

³⁹ Determined by multiplying the two probability figures together.

MOM 1-282672421-1, dated 15 February 2007, introduced a procedure for a visual inspection of contactors and the panel backplane to check for signs of over-heat, and a resistance check of the panel (ELMS 2 only).

MOM 1-294633521-1, dated 23 February 2007, informed operators that a '*non-conforming grade of FR4 back plane material*' had been used in ELMS 2 power panels which had undesirable thermal properties. This MOM re-iterated a recommendation to perform resistance checks.

MOM 1-300947576-1, dated 16 March 2007, informed operators that several reports of loose power feeder cable connections had been received. It noted that this could result in thermal build-up at the terminals and recommended that operators install a split ring lock washer. [This procedure was later detailed in SB 777-24-0105, dated 23 August 2007].

MOM 1-265810637-9, dated 21 March 2007, recommended that operators perform a torque check of all the nuts securing power feeder cables to the P100, P200 and P300 panels. It also recommended that operators use dual power sources⁴⁰ during ground operations to reduce heat build-up.

MOM 1-325491736-1, dated 8 May 2007, provided more information on the resistance check and lock washer installation.

MOM 1-441341331-1, dated 24 July 2007, informed operators of planned design improvements including active cooling of P200 and P300 panels, and incorporation of melamine backplane material in the ELMS 2 panels.

MOM 1-680024730-1, dated 12 November 2007, summarised the above MOMs and provided a summary of the panel and contactor failure events to date. This MOM was accompanied by the Fleet Team Digest 777-FTD-24-07002.

In October 2007 the aircraft manufacturer issued Service Bulletin 777-21-0114 which installed active cooling to the P200 and P300 ELMS 2 power panels. In March 2008 the aircraft manufacturer issued Service Bulletin 777-21-0117

⁴⁰ Dual power sources on the ground means using the APU and one external power source to power the electrics (APB and PEPC active), or using two external power sources (PEPC and SEPC active).

which installed the same active cooling modification to the P200 and P300 panels on ELMS 1. This cooling modification redirected airflow from nearby cooling ducts directly into the rear of the power panels. Tests and modelling revealed that the cooling modification reduced internal contactor temperature by about 80°C and bus temperature by between 60° to 80°C – see Figure 48.

The aircraft manufacturer considered that active cooling of the P100 panel was not necessary as failure events and in-service inspections revealed that the P100 panel was not suffering from over-heat issues.

Service Bulletin 777-21-0114 also covered replacement of the FR4 backplane material in the ELMS 2 panels with the same melamine material used in the ELMS 1 panels. This was due to the discovery of the poor thermal characteristics and dielectric breakdown properties of FR4.

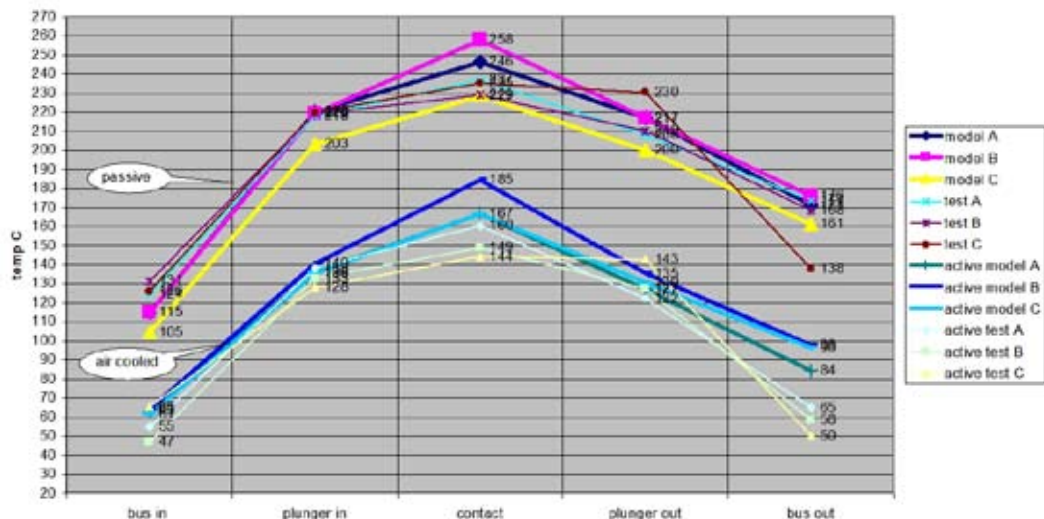

Figure 48

Temperature comparison between active and passive panel cooling for different locations within the panel. Ambient temperature was 20°C. Results also show difference between test results and thermal modelling

An additional change to the P200 and P300 power panels was an upgrade to the feeder terminations and terminal posts for the APB circuit in new production panels.

1.18.4.2 Containment tray modification

In order to prevent molten metal from a failed component dropping down on to insulation blankets and igniting them, the aircraft manufacturer and power panel

manufacturer developed a containment tray modification. This modification installs a 1.6 mm thick aluminium tray at the open base of the P100, P200 and P300 power panels – see Figures 49 and 50.



Figure 49

Photograph of the aluminium containment tray

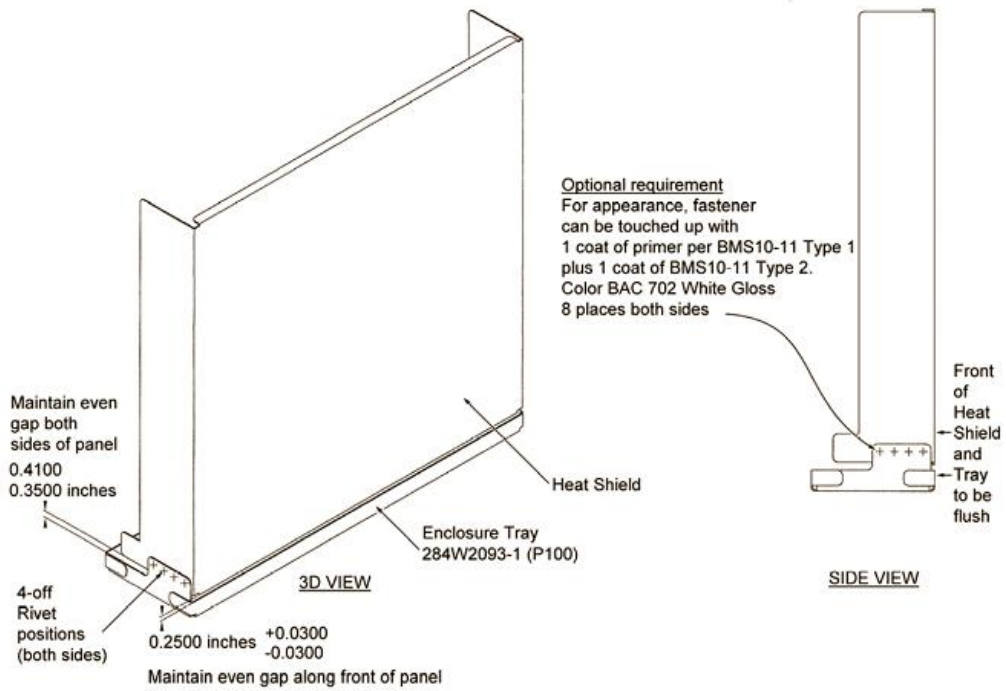

Figure 50

Diagram of containment tray (also known as enclosure tray) installation beneath the power panel

Thermal modelling revealed that when a piece of copper, 10 x 10 x 2 mm⁴¹, at an initial temperature of 1,000°C was placed on the aluminium containment tray with an initial temperature of 60°C, the containment tray reached a peak temperature of 500°C before cooling down. The melting temperature of aluminium is 660°C, so the modelling showed that the tray would not melt and would contain the hot copper. The melting temperature of copper is 1,084°C, so this modelling replicated the scenario involving a molten copper droplet falling onto the tray. The melting temperature of silver is 961°C so molten silver droplets of the same size would also be contained. Other materials inside the contactor such as nickel and steel have higher melting temperatures than copper, but there is significantly less of these materials in the contactor than there is copper and silver.

The containment tray modification was published on 20 July 2007 in Service Bulletin 777-24-0106 and this bulletin stated that:

'Accomplishment of the changes in this service bulletin will prevent a possible fire and or smoke and subsequent damage to insulation blanket and wiring below Electrical Load Management System (ELMS) panels. An ELMS contactor failure in a P100, P200 or P300 power panel can create molten debris. If the molten debris from the overheated ELMS contactor is not contained, damage to components from smoke and heat can occur and the smoke and heat can cause injury to persons.... The enclosure tray will contain the debris and prevent hot debris from falling on the blankets and components below the ELMS panel in the event of a contactor failure. Containment of the hot debris will prevent damage from smoke and heat and reduce the risk to personal safety.'

The aircraft manufacturer recommended compliance with this Service Bulletin within 60 months (5 years) of the date of the bulletin.

In July 2007 the AAIB informally recommended to the US Federal Aviation Administration (FAA) that the containment tray Service Bulletin should be made mandatory via an FAA Airworthiness Directive (AD). In September 2007 the AAIB and NTSB recommended that the compliance period of the SB be reduced from 60 months to 24 months or less. The FAA agreed that an AD was warranted and after discussions with the aircraft manufacturer decided on a compliance period of 36 months. At the time of writing the FAA was preparing a 'Notice for Proposed Rule Making' (NPRM) with the details of the AD.

41 These dimensions are an estimate based on the size of molten copper and silver 'blobs' found in previous incidents (after flattening and solidifying).

1.18.4.3 Implementation of a flight deck smoke warning

In the N786UA accident the smoke detector in the MEC detected smoke and this triggered an 'EQUIP COOLING OVRD' advisory message on the EICAS. There was no message or warning system that alerted the flight crew directly to the fact that there was smoke in the MEC. The aircraft manufacturer has since developed a software change to the AIMS (Airplane Information Management System) which will cause a 'SMOKE EQUIP COOLING' caution message to appear on the EICAS with associated aural warning, instead of the 'EQUIP COOLING OVRD' advisory message with no aural warning. This software change is due to be implemented on Boeing 777 Freighter aircraft but the aircraft manufacturer has not committed to including it on Boeing 777 passenger aircraft.

The new 'SMOKE EQUIP COOLING' message will be accompanied by a new checklist which replaces the previous 'EQUIP COOLING OVRD' checklist. The new checklist replicates the instructions from the previous checklist and adds a new instruction to '*Plan to land at nearest suitable airport*' in the event that the 'SMOKE EQUIP COOLING' message remains displayed after performing the checklist items.

1.18.4.4 Safety action taken by the contactor manufacturer

The contactor manufacturer has carried out a number of modifications to the ELM 827-1 and ELM 828-1/-2 contactors in response to the N786UA accident, other contactor failure events, product repairs, and information gained from the high cycle/ high time contactor study. These modifications apply to new production contactors, although some of these modifications are also embodied when contactors are returned for repair and reconditioning. The changes to the contactors, which include some manufacturing process changes, are listed in chronological order below (the date of production incorporation is approximate):

- 1) January 2007: The arc chute material was changed from Zytel FR-10 to Ryton to avoid warp when it was cooled after moulding.
- 2) February 2007⁴²: A new riveting process, using a solid rivet, was implemented for the junction between the silver pigtail foil and the movable contact assembly. This change

⁴² The February 2007 modifications were incorporated as Mod 07 for the ELM827-1 contactor and Mod 03 for the ELM 828-2 contactor.

was designed to prevent loosening under high temperature conditions.

- 3) February 2007: The maximum permitted phase voltage drop in the FTP was reduced from 225 mV to 175 mV. This ensured that new contactors would have lower internal resistance and therefore generate less heat at the same current.
- 4) February 2007: Additional voltage drop measurements were added to the FTP to include each mechanical junction within the conductor path. These manufacturing parameters were recorded and formed part of a new statistical process control.
- 5) May 2007: Loctite was added to the screws which retain the arc chute, in order to prevent them from coming loose under high heat conditions.
- 6) May 2008⁴³: A Teflon tape wrap was added around the pigtail foils within half an inch of the movable contact assembly. This change was designed to secure the foils and prevent movement in the event of a foil leaf breaking.
- 7) May 2008: The type of threaded insert in the movable contact support bar was changed to include a flange. This new type of insert was designed so that it would not dislodge in the event of high temperature operation.
- 8) May 2008: A glass Teflon insulating sheet was added to cover the plunger assembly hardware. This modification provides additional barrier material to prevent conductive materials from getting into the spaces between phases on the contactor base. It may also serve to prevent a short-circuiting event in the area of the main contacts from migrating to the contactor base and into the power panel.
- 9) May 2008: A glass Teflon insulating tube was added around the central movable pigtail assembly to provide a barrier between pigtails. This modification is also designed to reduce the risk of a short-circuit event between phases.

43 The May 2008 modifications were incorporated as Mod 08 for the ELM827-1 contactor and Mod 04 for the ELM 828-2 contactor.

- 10) May 2008: The plastic insulator sleeves around the terminations of the monitor wires were removed. It was observed that in some contactors that had experienced high heat conditions, the plastic insulator sleeves had become brittle and broken off. This posed a hazard from free floating debris, and since insulation was considered unnecessary at the terminations, the sleeves were removed.
- 11) Planned modification for end of 2008⁴⁴: The geometry and material of the arc chute will be changed. The material will be changed from Ryton (a thermoplastic) to Dielectrite (a thermoset) which will not melt at high temperatures and has improved resistance to dielectric breakdown. The geometry of the arc chute will also be changed to make it taller and deeper to reduce the risk of a short-circuit between main contact phases and reduce the risk of a short-circuit between main contacts arcing across and destroying the contactor cover. The dimensional changes to the arc chute can be seen in Figures 51 and 52.

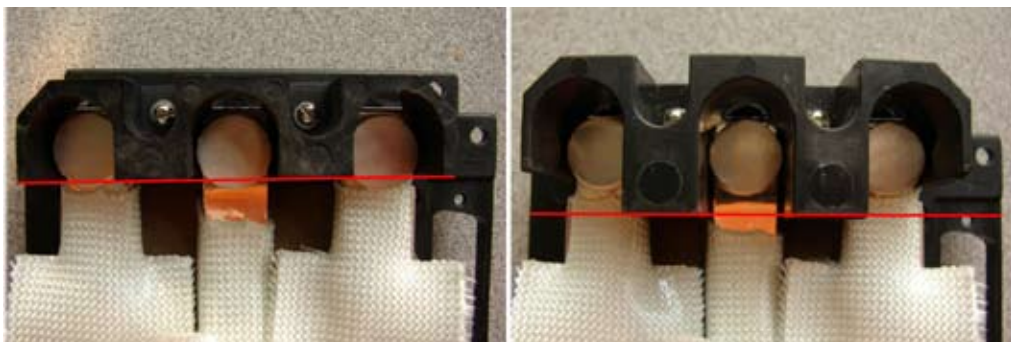

Figure 51

Top view of old arc chute (left) versus new taller and deeper arc chute (right)
– the red lines highlight the difference in size of the protected area

⁴⁴ The planned modifications for end of 2008 will change the ELM827-1 part number to ELM827-3 and the ELM828-2 part number to ELM 828-3, as these changes are considered major modifications and require re-qualification.

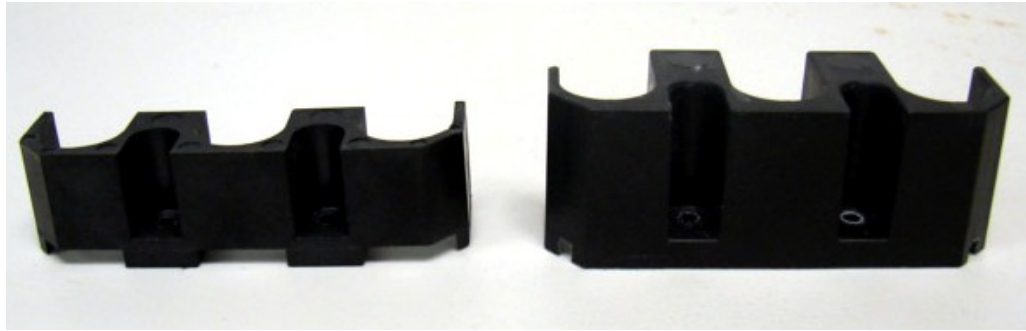

Figure 52

Front view of old arc chute (left) versus new taller and deeper arc chute (right)
– note increased protection at the base of the new arc chute

- 12) Planned modification for end of 2008⁴⁴: The mechanism for attaching the silver pigtail foils to the stationary contacts will be changed. The existing assembly compresses the stationary contact, pigtail foils, and stationary contact support block together using a screw and nut. High temperature operation can cause the support block to soften which can cause this connection to loosen. The modified design separately attaches the pigtail foils to the movable contact assembly with a nut, washer and lockwasher, before attaching the entire assembly to the support block – this provides for a more secure and heat resistant conductive joint.

Event/Exam Findings	Mitigating Action	Implementation	
		ELMS 1	ELMS 2
<p>Blankets Exposed to molten metal, combustion extended beyond ignition area before self-extinguishing</p> <p>Contactors Overheating in-service Foil leaves severed, clamp plates bowed, rivets loose Wear particles on aux contacts Contact erosion Material variations Stationary contacts sagging Operator bar inserts migrating Arc debris found on internal components Arc shield does not fully isolate contactors Loose hardware</p> <p>ELMS Panels Low thermal margin with some variability High resistance connections to power feeders ELMS 2 FR4 backplane poor thermal characteristics P300/APU circuit prone to overheat</p>	Containment Tray	Boeing SB 777-24-0106 (Jun 07) GE SBs: 1000ELM-24-666, 2000ELM-24-667, 3000ELM-24-668 FAA Planned AD	ELMS 2
	Dual Ground Power Operations	Boeing MOM 1-680024730-1 (Nov 07)	
	Statistical process control, reduction in internal resistance New solid rivet	Contact Revision Mod 7 (Current standard)	
	Insulate plunger nuts Pigtail sleeves / phase barriers Change insert for operator bar Monitor wire insulation	Contact Revision Mod 8	
	Change material and dimensions for arc chute Revise stationary contact to avoid plastic in compression	New Contactor P/N ELM827-2 (Mod 9)	
	ELMS Panel and Contactor Inspections	Boeing MOM 1-680024730 777-FTD-24-07002	Boeing MOM 1-282672421-1 (GE LS-DE42771)
	Active cooling	Boeing SB 777-21-0117 (Mar 08)	Boeing SB 777-21-0114 (Oct 07)
	ELMS 2 backplane replacement	N/A	
	Add lock washer to power feeder terminations	Boeing SB 777-24-0105 (Aug 07)	
	APU circuit improvements in P300	Production – Line Number 747 and all 777 Freighters	

Table 2
Summary of the primary safety action taken

2 Analysis

2.1 Electrical failure event sequence

The aircraft was serviceable and there were no indications of any problems until the right IDG came online after engine start. The right IDG was designed to come online approximately 6 seconds after the right engine N2 reached 51% - this would have occurred at approximately 1000:41 hrs and this was when the RGCB would have been commanded to close. Three seconds¹ later the first indication of a failure event occurred when the BPCU detected a problem with the RGCB auxiliary contact position. Within two seconds of this failure detection, there were two additional simultaneous failure indications: (1) both the BPCU and RGPU detected a right main bus under-voltage and (2) an intermittent unusual noise was heard on the CVR which was later described by the flight crew as a 'growling' noise coming from the region where the P200 power panel was located.

From an examination of the damage in the MEC, the only explanation for the origin of the 'growling' noise was from either the RGCB or RBTB contactor. The noise was probably caused by intermittent internal arcing and short circuit events. The noise started at the same time that a bus under-voltage was detected which would be triggered if a short circuit event was occurring within the RGCB, robbing the bus of power from the right IDG. The symptoms experienced by the flight crew, flickering displays and the 'ELEC AC BUS R' failure caution message, are consistent with the bus under-voltage detection.

A no-break power transfer (NBPT), resulting in the RBTB opening, should have occurred within 24 ms of the RGCB closing, so this should have been completed by approximately 1000:41, before the first failure indications. There were no failure messages to indicate that the RBTB had not opened or that the RBTB had not been commanded to open. There was also no message indicating that Sustained Parallel Source (SPS) protection had activated, so this evidence suggests that the failure event occurred after a successful NBPT.

It was not initially apparent which contactor failed first. The RBTB had suffered significantly more heat and arc damage than the RGCB. The RBTB experiences 6 switching operations (3 cycles) per typical flight compared to just two switching operations (1 cycle) for the RGCB, suggesting that the RBTB might wear out more quickly than the RGCB. Opening contacts are more likely to generate arcs than closing contacts and are therefore more likely to initiate a failure event; it was the RBTB which was opening during the

¹ This could have been less than three seconds as the time of the right IDG coming online is not known exactly.

NBPT after the RGCB closed. This evidence suggests that the failure event was more likely to have initiated in the RBTB than the RGCB. However, the initial NVM fault messages were all associated with the RGCB. For the first 23 seconds after the initial failure was detected, there were three failure messages relating to incorrect RGCB contact state based on auxiliary contact position. After 23 seconds the first message relating to an RBTB fault occurred. This evidence clearly points to the RGCB as being the initial failure point. The first three RGCB failure messages can be explained by internal arcing and short circuits damaging the auxiliary contact wiring, resulting in disagreements over the sensed auxiliary contact position. If the RGCB had failed first and was suffering from internal arcing then it is quite possible that within 23 seconds the casing became compromised and molten metal dropped down onto the RBTB below. This molten metal would have compromised the RBTB's casing and initiated short circuits and arcing within it. The GSR sits directly below the RBTB and it was clear from the GSR damage that it had been compromised by molten material dropping down from the RBTB.

Twenty seconds after the failure event was first detected, 'Feeder Differential Fault Protection' was activated. This removed power from the right IDG by tripping the GCR² and it also commanded the RGCB to open. Even if the RGCB had failed to open, the power source to the RGCB that was feeding the arcing would have been removed. However, the RBTB was still receiving power from the APU generator, and any short circuit across the contacts of an individual phase within the RBTB would have sent this power to the right bus and to the RGCB. The reason for the 'Feeder Differential Fault Protection' activation was not clear. It is designed to detect and protect against shorts within the feeder cables between the IDG and the P200 panel, but no such short circuits occurred. The cables and their connections to the panel had not been compromised. One explanation is that the internal arcing of the RGCB and RBTB induced high current transients detected by the Current Transformers (CT) that were used to detect a short circuit within the feeder cables. These CT readings then caused 'Feeder Differential Fault Protection' to be activated. So this protection was not activated by design but in error, although it probably helped to reduce the severity of the failure. The flight crew shut down the right engine 3 minutes later but this had no effect on the event as the right IDG had already been de-excited by differential protection.

The unusual, intermittent, growling noise continued for at least 2 minutes and 58 seconds after the initial failure event. If the noise was associated with the sound of arcing then that was a long time for the arcing to have continued

² Tripping the GCR (Generator Control Relay) de-excites the generator. The generator will continue to spin but will not deliver any power.

unchecked. The source of power for this continued arcing could only have come from the APU generator, as the right IDG had been de-excited and the left IDG was isolated via an open LBTB. The APU was not shut down until 1014:00 hrs, so until this time the APB remained closed, delivering power directly to the failed RBTB. However, before this time the RBTB had probably suffered sufficient damage to cause an open circuit to form, preventing the APU generator power from feeding further damage.

2.2 Electrical system protection

The internal arcing of the RGCB and RBTB continued unchecked for a long time without activating any protection logic, besides the erroneously activated 'Feeder Differential Fault Protection'. The NVM data revealed that no 'Unbalanced Current Protection', no 'Through Fault Protection', and no 'Under-voltage Protection' was triggered by the failure event. This was because of the time delays involved in activating these protection functions. Unbalanced Current Protection requires a current difference between phases of more than 100 A. It was probable that a current difference of at least that amount existed in the failure event, but it did not last long enough for it to trigger the protection (up to 16 minutes can be required, see section 1.6.6, page 15). The nature of the arcing in the failure event was probably intermittent (the 'growling' noise was intermittent), so it could cause high current fluctuations without triggering the protection. The same applies for 'Through Fault Protection' with its minimum 7 second duration time and for 'Under-Voltage 1 (UV1) Protection' with its minimum 9.5 second duration time.

These time delays exist as part of the protection logic in order to allow time for downstream circuit breakers to activate for the more common downstream faults, thereby preventing unnecessary power removal from the whole bus. The negative side-effect is that upstream faults at the primary contactors are less protected. The system designers assumed that the contactors were sufficiently robust (and this was based on test data) that the type of failure seen on N786UA would not happen.

Reducing the time delays would seem to provide an obvious solution for protecting against contactor failures of the type seen on N786UA. However, the aircraft manufacturer argued that reducing these times would result in an increased exposure to nuisance trips, and that even very short times might not be sufficient to protect against severe contactor faults.

An alternative way to protect against contactor faults would be to install current transformers at the input and output ends of the contactor, so that an

internal short circuit could be immediately detected and its location pin-pointed. This would essentially provide differential fault protection of the contactors themselves. If the failure occurred inside the GCB then power from the input IDG would be removed. If the failure occurred inside the BTB then the tie bus would be isolated by opening and locking out the APB and opposite BTB. This would isolate the fault. However, the aircraft manufacturer argued that implementing such a change would involve a costly redesign, re-qualification and re-certification of the power panels and the system. It argued that it would be more efficient and more cost effective to improve the contactor to make it more robust and therefore more resistant to breakdown. It also argued that pursuing a system redesign was unnecessary given that the containment tray modification (see safety action 1.18.4.2, page 71) would protect the aircraft from a future contactor breakdown.

The aircraft manufacturer believes that the containment tray modification should be sufficient to reduce the risk of a recurrence of the N786UA failure event to an acceptable level. However, the aircraft manufacturer should adopt lessons learnt from this investigation when designing new electrical systems for future aircraft. The AAIB therefore recommends that:

Boeing Commercial Airplanes should consider implementing differential current fault protection of main power contactors when designing future electrical systems. **(Safety Recommendation 2009-021)**

2.3 Possible causes of contactor failure

The failure event started either inside the RGCB or the RBTB contactor, but most probably inside the RGCB contactor. Both contactors were of identical design and were manufactured during the same month. The contactors had suffered such severe internal damage that it was not possible from a visual examination to determine the initiating point of failure, but it was apparent that both had suffered from internal arcing and short circuits which had generated temperatures in excess of 1,000°C. The severest damage in both contactors was concentrated around the main contacts and the stationary contact plunger nut assemblies. Information obtained from an examination of high time/ high cycle contactors from the fleet, examination of contactors from other failure events, a review of repair records, and the results of an endurance test were used to examine the possible causes of the failure.

The evidence pointed to an internal fault with the contactor although an external trigger was considered. An excessively high fault current or repeated high

current transients during power transfers could have damaged the contactor. However, there was no evidence to indicate that the system had generated a high fault current, and N786UA has continued to operate without a repeat of the fault since the power panel was replaced. In addition, the results from the ground test did not reveal any evidence of excessive high current transients during power transfers. Therefore, an internal fault of the contactor was considered to be the most probable cause.

The possible causes of contactor failure can be categorised as being heat-related or non-heat-related.

2.3.1 Heat-related possible causes of contactor failure

The contactors operate at high temperature. The contactor endurance test revealed that the main contacts reached a temperature of 225°C after 45 minutes of operation at 345 to 354A. This level of temperature did not cause any problems to the contactor under test. However, a loose junction can increase the junction resistance and increase its temperature. The ensuing temperature increase can act to further loosen the junction, resulting in a further temperature increase and an ensuing vicious circle. The contactor in the January 2008 incident on A6-EBV was estimated to have reached a temperature of 540°C based on the reflow of braze material. Many of the ELMS 2 failure incidents appear to have been caused by high heat build-up. Five of the contactors in the high-time/high-cycle study had evidence of over-heat, and some contactors returned for repair have also had evidence of high heat exposure. Some of the possible consequences of excessive heat build-up are summarised below:

1. Melamine starts to soften at 300°C and this was the material used for the contact support block in the failed RGCB and RBTB. As the material softens the stationary contacts can start to sink. If they sink sufficiently, the contact force will reduce, resulting in further temperature increase due to the increased contact resistance. If they sink sufficiently to open a gap, then continuous arcing across the contacts could occur, resulting in significant arc splatter, arc plasma and eventual phase-to-phase arcing and ensuing contactor breakdown. Later models of contactor used Ryton as the contact support block material, which melts at 282°C, and would have a similar effect to melamine. Evidence of reduced over-travel gap due to this 'sinking' effect was found in some of the contactors examined. Contactors made after 1997 have Dielectrite contact support blocks which are far more temperature resistant. Dielectrite does not start to break down until 510°C and therefore mitigates against this potential hazard. A further

planned mitigation for contactors manufactured towards the end of 2008 is a change to the stationary contact support block fastening mechanism (reference item 12 from safety action section 1.18.4.4, page 77).

2. Excessive heat build up can result in the movable contact spring or the plunger spring annealing and becoming 'heat set', reducing its set length and thereby reducing its spring force. A reduction in spring force will result in a reduction in contact force and a subsequent increase in resistance and temperature. Complete loss of contact force can result in continuous arcing and contactor breakdown. Contactors have been examined which have had 'heat set' springs in both the movable contact assembly and the plunger assembly, but it has not been possible to establish whether this was an initiating cause or an effect of heat build-up due to other reasons.
3. Excessive heat build-up can result in screws coming loose and these screws can cause a short-circuit which can result in contactor breakdown. One of the contactors from the high-time/ high-cycle study had a loose arc chute screw which was completely free to roll around inside the contactor. Also, the repair records revealed a contactor with a loose screw from the auxiliary contact operator assembly. Either screw could have caused a short-circuit hazard. The screws from these locations were accounted for and still in place in the failed N786UA RGCB and RBTB contactors, and therefore did not cause the failures. However, loose screws could cause future contactor failures. New contactors are manufactured with Loctite adhesive on these screws in order to prevent them from loosening under high heat conditions and thereby reducing the risk of a short-circuit.
4. Excessive heat build-up can result in the degradation and break-up of insulating materials which can pose a subsequent debris hazard. A number of the contactors examined which had evidence of over-heat also contained flakes of epoxy which had flaked off from the phase barriers. Some also contained pieces of heat-damaged plastic terminal insulation from the sensor wiring. These pieces of insulation could become jammed inside the armature gap, preventing full main contact closure and subsequent arcing damage. Alternatively, the pieces of insulation could end up on the main contact faces, increasing contact resistance and raising contact temperature. These were potential causes of the N786UA failures. To mitigate against these hazards, the contactor manufacturer has replaced the epoxy coated phase barriers with glass fibre insulation sheets and has removed the terminal insulation from the sensor wires.

5. Excessive heat build-up can result in degradation of the arc chute. The Teflon arc chute used in the N786UA contactors has a melting temperature of 342°C. If the arc chute melts sufficiently, an air gap will open up between main contact phases which could result in phase-to-phase arcing as a result of arc splatter and arc plasma. Limited evidence of Teflon melting has been found although melting of an arc chute made of Zytel (melt temperature of 305°C) was clearly evident in the failed contactor from the December 2004 incident on aircraft 9V-SVO (see Figure 39, page 51). A planned modification for contactors built towards the end of 2008 is to manufacture the arc chute from the more temperature resistant Dielectrite material (reference item 11 from safety action section 1.18.4.4, page 76).
6. Excessive heat build up can result in displacement of the threaded insert in the contact support bar; the movable contact pushrod screws into this insert. Some contactors that had been exposed to excessive heat exhibited this condition. Heat conducted through the pushrod had softened the contact support bar material, and caused the threaded insert to push upwards in response to the force from main contact closure. This resulted in an increase of the contactor gap when open and a reduction in over-travel when closed. A sufficient displacement of the threaded insert could result in a complete loss of main contact force and subsequent excessive arcing and contactor breakdown. This was a potential cause of the N786UA failure. In May 2008 the contactor manufacturer introduced a modification to the threaded insert to include a flange to prevent upwards movement due to high temperature (reference item 7 from safety action section 1.18.4.4, page 75).
7. As previously discussed, any loose junction within the conductive path can result in increased heat build-up. One junction that was particularly susceptible to loosening was the junction between the silver pigtail foils and the movable contact assembly. In February 2007 the contactor manufacturer introduced a new riveting process, using a solid rivet, to prevent loosening under high temperature conditions (reference item 3 from safety action section 1.18.4.4).

2.3.2 Non-heat-related possible causes of contactor failure

Non-heat-related possible causes of the contactor failure, such as mechanical failure and manufacturing defects, were also considered.

1. Arc spray deposits on the stationary contact support block could create a conductive pathway for a phase-to-phase short circuit. When ERA examined the high-time/ high-cycle contactor CL-83606 it discovered arc

spray deposits containing aluminium on the stationary contact support block between phase A and B (see Figure 46, page 61). This was along the 2 mm edge of the support block that was not protected by the arc chute. If deposits such as these built up sufficiently to bridge the gap between the phases, a short circuit would occur. This would most likely result in the deposits vaporising in an arc flash, resulting in the open circuit being restored. However, ERA argued that if there was sufficient heat in the melamine support block (or Ryton in some contactors), the arc flash could cause the melamine to char and become electrically conductive, ie dielectric breakdown would occur and result in arc tracking through the carbon in the material. This is a phenomenon that has been observed before in printed circuit boards. The contactor manufacturer considered this scenario very unlikely and commented that it was very unlikely that arc spray would land in a continuous path across the flat surface of the contact support block not covered by the arc chute.

The source of the aluminium in the arc spray deposit on contactor CL-83606 could not be conclusively established. However, the internal components made of aluminium were undamaged, so it was probable that the aluminium was introduced as debris during manufacture. In contactors without foreign debris it is possible that silver arc spray deposits from the silver cadmium contacts could also bridge the gap between phases although this has not been observed in any of the high-time/ high-cycle contactors. All the contactors examined during the high-time/ high-cycle study passed the dielectric withstand test across the support block, so the formation of conductive deposits is not common, but cannot be ruled out as a possible cause of failure in the N786UA failure event.

A planned modification for contactors built towards the end of 2008 is to change the dimensions of the arc chute. The new arc chute is significantly taller and deeper (see Figure 52, page 77) and will completely cover the stationary contact support block, preventing arc spray deposits from forming in the first place. It will also serve as a significantly more robust insulating barrier between main contact phases, that will reduce the likelihood of phase-to-phase arcing following any internal failure event (reference item 11 from safety action section 1.18.4.4, page 76).

2. A broken pigtail foil could have initiated a short-circuit which precipitated contactor breakdown. Six of the contactors examined during the high-time/ high-cycle study contained broken silver pigtail foils (see Figure 41 for an example, page 55). The contactors contain insulating sheets that reduce the likelihood of a broken foil making contact with ground or

an adjacent phase, but the possibility could not be ruled out. Therefore, the contactor manufacturer carried out a test to determine the effect of a short-circuit through a pigtail foil. The tests showed that the pigtail foil vaporised instantly (acting like a fuse) eliminating the short-circuit pathway. However, it is possible that the vaporised silver material and generated arc plasma could introduce a secondary failure, and this was a possible although unlikely cause of the N786UA failure. The contactor manufacturer introduced a simple modification in May 2008 that adds a Teflon tape wrap around the pigtail foil ends. This tape prevents pigtail foil movement in the event of breakage (reference item 6 from safety action section 1.18.4.4, page 75).

3. Contact chatter could result in excessive arcing and resulting heat build-up and arc splatter that could cause contactor breakdown. Some of the contactors in the high-time/ high-cycle study exhibited contact chatter when actuated using 15 VDC. However, the operating voltage on the aircraft would be closer to 28 VDC and this was confirmed by the ground test. Unless significant erosion of the auxiliary contact ‘throat-cutter’ blades had occurred, the contactor coil would ‘see’ 28 VDC and in no cases did voltage this high result in chatter. The ‘throat-cutter’ blades on the RGCB and RBTB from N786UA did not exhibit significant erosion, despite the heat damage. Any contact chatter would be limited to 200 ms, as this is the time limit after which the GCU removes coil voltage. It was therefore considered unlikely that contact chatter was the cause of the N786UA failure event.
4. The consequences of heat-related debris were discussed in section 2.3.1. The possibility of non-heat-related debris causing a short-circuit also existed. One of the high-time/ high-cycle contactors contained a broken auxiliary contact blade, and repair records between 1994 and 1996 revealed three additional incidents of broken auxiliary contact blades. During the contactor endurance test, a 4 mm solder ball and an 8 mm brass shim were found free inside the contactor cover. All of these contactors contained free conductive material that posed a short-circuit risk. Although the auxiliary contact blades on the RGCB and RBTB from N786UA were all intact, the possibility of other conductive material having broken off or having been introduced during manufacture could not be ruled out as a possible initiating cause of failure.
5. A welded main contact in the RBTB could have resulted in parallel sourcing for an excessive time period following the NBPT, resulting in high currents, high heat and contactor breakdown. One contactor that was returned to the manufacturer for repair had a welded main contact. If a single main contact

has welded, all the contacts will be prevented from opening. If a contactor is commanded to open and it fails to open due to welding than a trip fault will occur and in the case of an NBPT, Sustained Parallel Source (SPS) protection will activate and protect the system. However, this protection is dependent upon the auxiliary contacts correctly sensing that the contactor has not opened. According to the contactor manufacturer, it would be possible for the armature to move upwards sufficiently to change the auxiliary contact state while the main contacts remained welded (this is because of the springs). This would 'fool' the system into thinking that the contactor had opened even though the contacts were still closed. However, within 200 ms the coil voltage would be removed and the armature would settle back down into its closed position, the auxiliary contacts would now sense closed, and this would then correctly trigger SPS. Therefore, in this failure situation the duration of parallel sourcing would be limited to 200 ms, and the contactor is likely to be able to withstand any high fault currents for this time period.

A more serious case of a welded contact would occur if a movable contact pushrod failed. If a pushrod failed, the movable contact would remain in the closed position while the other two movable contacts moved to the open position. Welding of the movable contact would not be necessary in this scenario but the effect would be the same. The armature would travel to its full open position and the auxiliary contacts would all indicate open, while a single movable contact remained closed. No protection systems would activate. The closed movable contact would still be conducting current, and assuming this occurred in the RBTB following the NBPT, eventually the parallel sources would become out of phase and very high and sustained fault currents would ensue, resulting in potential contactor breakdown. However, this scenario does not fit the evidence which indicates that the RGCB failed before the RBTB. Furthermore, the failure of a pushrod is an unlikely failure as no such failure has ever occurred in this type of contactor. Therefore, a welded contact or failed pushrod was an unlikely cause of the N786UA failure event.

6. Excessive contact erosion over time could result in a complete loss of contact force and subsequent contactor breakdown due to continuous arcing and excessive heat build-up. The 50,000 cycle endurance test revealed that most contact erosion occurred during the first 15,000 cycles and then reduced to a lower wear rate. Over the 50,000 cycles only 0.004 inches of over-travel was lost, resulting in 0.019 inches of over-travel gap remaining. The average remaining over-travel gap from the high-time/high-cycle contactors was 0.014 inches. This evidence suggests that a loss of over-travel due to erosion would be unlikely. However, if the over-

travel gap was miss-set too low during assembly, then small amounts of erosion could result in a loss of over-travel and loss of contact force. Two contactors from the high-time/ high-cycle study had remaining over-travel gaps of only 0.002 inches – these were not far from losing all over-travel. The over-travel gap set during assembly is not recorded so it was not possible to establish why the over-travel gap on those contactors was so low, although heat build-up was probably a contributing factor and had reduced the spring force. Loss of contact force due to erosion, assembly errors, and or excessive heat build-up, could not be ruled out as a factor in the N786UA failure event.

2.3.3 Summary of possible causes of contactor failure

A number of possible causes of contactor failure have been considered, but there was insufficient evidence to select a most probable cause of failure. The diagram in Figure 53 summarises all the possible causes considered. Nevertheless, the most likely causes were: i) a debris induced short-circuit or debris induced fouling of the armature or ii) a loss of over-travel due to a combination of heat build-up, erosion and possibly assembly errors. A third possibility was arc tracking across the unprotected region of the stationary contact support block.

The 50,000 cycle endurance test was carried out to help determine a possible failure mechanism. In the test, no failure occurred and the contactor was demonstrated to be reasonably robust. However, it must be remembered that this contactor was carefully assembled and included a number of modifications and material changes compared to the failed N786UA contactors. Further modifications and improvements to the contactors are planned for end of 2008, most important of which is the revised taller and deeper Dielectrite arc chute. This change, in conjunction with all the other previously mentioned changes, should result in a contactor that is significantly more resistant to failure than the N786UA contactors manufactured in 1995. These new contactors will be installed on all new production Boeing 777 aircraft, although there is currently no requirement to retrofit these contactors to the fleet. The AAIB considers that, in light of the N786UA failure event, there would be a safety benefit to retrofitting these new contactors. The AAIB therefore recommends that:

The Federal Aviation Administration, in conjunction with the European Aviation Safety Agency, should consider mandating the replacement of ELM 827-1 contactors with ELM 827-3 contactors on all Boeing 777 aircraft, to reduce the risk of a contactor breakdown that results in uncontained hot debris. (**Safety Recommendation 2009-022**)

Auxiliary contact blade failure was not a factor in the N786UA accident, but it was identified as a possible short-circuit risk that might cause a future contactor failure. Four contactors were identified during the investigation that contained broken blades. The contactor manufacturer has not made any modifications to the auxiliary contact blades to make failure less likely. The AAIB therefore recommends that:

Tyco Electronics Corporation should introduce mitigating action to reduce the risk of auxiliary contact blade failure in ELM 827 and ELM 828 contactors, in order to prevent a broken blade from causing a short-circuit failure. **(Safety Recommendation 2009-023)**

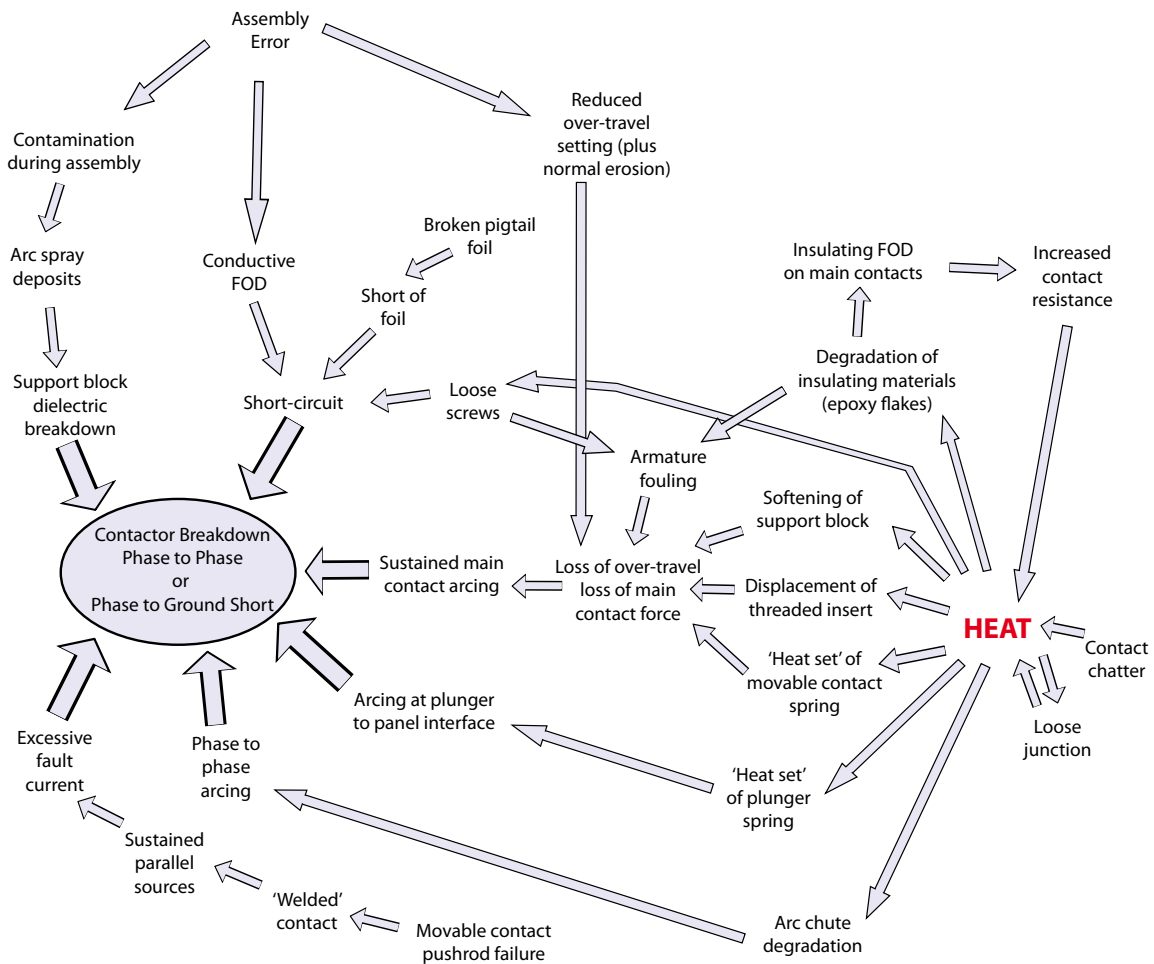

Figure 53

Diagram listing possible causes of contactor failure

2.4 Probable cause of previous power panel failures

There have been a number of power panel and contactor failures both before and since the N786UA accident. Most of these involved ELMS 2 panels. Of the four incidents resulting in major damage, three of them were attributed to loose connections within the power panel. A loose bus bar or terminal lug connection was not a factor in the N786UA accident, so this was not a subject of detailed investigation, although the power panel manufacturer has taken steps to remedy some of these problems. A further problem with the ELMS 2 panels has been the additional heat generated due to greater power demands than from the ELMS 1 panels. Furthermore, the FR4 backplane material used in the ELMS 2 panels, unlike melamine used in the ELMS 1 panels, has revealed itself to be more susceptible to arc tracking following high heat exposure. Therefore, all new ELMS 2 power panels are being made with melamine backplane material and a Service Bulletin (Boeing SB 777-21-0114) was published in October 2007 calling for a retrofit replacement of the FR4 backplane material in power panels currently in service. This Service Bulletin is, however, not backed up by an Airworthiness Directive so compliance is not mandatory.

The same Service Bulletin calls for the installation of an active cooling modification for the P200 and P300 power panels on ELMS 2. This cooling modification was shown to reduce internal contactor temperature by about 80°C and bus temperature by between 60° and 80°C. This modification should help to reduce the risk of recurrence of a number of the failure events which were attributed to excessive heat build-up. The same cooling modification was introduced for ELMS 1 panels in March 2008 (SB 777-21-0117) due to its potential benefits in reducing the risk of contactor failure.

The cooling modification is also not backed up by an Airworthiness Directive and therefore compliance is not mandatory. However, the aircraft manufacturer has stated that approximately 60% of its Boeing 777 customers are planning on implementing the cooling modification, in particular airline operators operating in hot regions of the world.

It is difficult to generalise the cause of failure of the other previous failure incidents, but some appeared to be caused by contactor failure although the initiating fault was never conclusively determined. Many of the previous failure incidents involved the APB or PEPC contactor, both of which can become highly loaded during single source ground operations and are therefore more likely to suffer from a heat-related failure than a GCB or BTB. For this reason the aircraft manufacturer recommended that operators use dual power

sources during ground operations (MOM 1-265810637-9), to spread the load between the APB and the PEPC or between the PEPC and SEPC. The aircraft manufacturer is considering whether dual ground power source operation is still necessary on aircraft that have installed the cooling modification.

2.5 Fire and smoke in the Main Equipment Centre

The fire and smoke in the MEC was caused primarily by ignition of the insulation blankets from hot molten metal droplets falling down from the failed contactors. Some of the floor panel burning and ancillary equipment burning would also have contributed to the smoke.

2.5.1 Effectiveness of the fire retardant insulation blankets

Contamination on insulation blankets can affect its fire retardant capabilities and the aircraft manufacturer had warned operators about this hazard in a Service Letter (777-SL-25-018). The remaining insulation blankets on N786UA were tested for contamination and apart from one sample which contained CIC, no other evidence of contamination was found that could have affected the flammability properties of the insulation. However, the presence of CIC or other contamination on the blankets prior to burning, which had subsequently burnt, could not be ruled out. The cotton swab flame propagation test showed that even un-contaminated insulation will burn when exposed to a swab dipped in alcohol that is burning at 730°C, and in the failure event the insulation was probably exposed to molten metal droplets of around 1,000°C. The insulation blankets are not designed to be inflammable but are designed to retard any fire. In both the cotton swab test and the Bunsen burner test, the insulation self-extinguished and stopped the spread of fire. In the case of the N786UA failure the fire spread along the insulation to the P205 panel on the opposite side of the P200 panel. It is probable that the heat build-up from the initial ignition of multiple molten droplets helped to spread the fire. The cotton swab test and Bunsen burner test are carried out at room ambient conditions. It is possible that the newer specification insulation (post-2005) which is designed to withstand radiant heat may have fared better in the failure scenario. Nevertheless, the insulation in the N786UA failure event did eventually self-extinguish; no source of fire was detected when the Airfield Fire Service personnel entered the MEC.

2.5.2 Flight crew awareness of smoke in the MEC

The flight crew did not become aware of any smoke until some time after the insulation blankets started to burn. The smoke detector in the MEC detected

smoke 42 seconds after the initial electrical failure event and this triggered the ‘Equipment Cooling Override’ mode. Three minutes and 13 seconds after the failure event the flight crew first noticed an electrical burning smell. It was not until 4 minutes and 30 seconds after the failure event that the flight crew became aware of smoke – this was when the tug driver advised on interphone that there was a lot of smoke coming out of the vents. No smoke was seen in the flight deck until after the APU was shut down – 14 minutes after the failure event. The flight crew’s lack of awareness of the significant smoke in the MEC may have delayed their decision to shut down and evacuate the passengers. Their focus was on the bus failure and a perception of an overheat problem; the possibility of a fire in the MEC appeared to have been dismissed. If the aircraft’s warning system had provided a ‘smoke’ warning to the flight crew when smoke was first detected, then the flight crew might have expedited the shutdown and evacuation. The aircraft manufacturer has subsequently developed an AIMS software update that will replace the ‘EQUIP COOLING OVRD’ advisory message with a higher level ‘SMOKE EQUIP COOLING’ caution message. This caution message will clearly notify the flight crew that there is smoke in the MEC and this message will also trigger the associated caution aural warning. This software change is due to be implemented on Boeing 777 Freighter aircraft but the aircraft manufacturer has not committed to including it on Boeing 777 passenger aircraft. Given the clear safety benefits of this ‘smoke’ message, the AAIB recommends that:

The Federal Aviation Administration, in conjunction with the European Aviation Safety Agency, should mandate that all Boeing 777 aircraft be equipped, at the earliest opportunity, with a software update that will generate a caution message to alert flight crew of the presence of smoke in the Main Equipment Centre.
(Safety Recommendation 2009-024)

2.5.3 Containing and preventing fire in the MEC

The fire in the MEC posed a risk to equipment and structure near the P200 power panel. In the event, the structural damage was limited and was assessed to be capable of sustaining in-flight pressure loads and ‘get-home’ limit loads had the failure occurred in flight. Some of the wires from the P205 panel were damaged and resulted in some spurious warnings being recorded by the FDR, but none would have affected the safety of flight. Additional wiring damage in this bundle would have triggered false warnings to the flight crew, including the possibility of a false left engine and right engine fire warning. If this had occurred in flight it would have proved very distracting and confusing to the flight crew.

The cargo bays on the Boeing 777 and on many other large transport aircraft contain fire-extinguishing equipment. The MEC on the Boeing 777 does not contain fire-extinguishing equipment. The design philosophy for the MEC is that all the internal equipment has been designed to meet certain safety standards to make fire unlikely. The same cannot be said about the cargo bays which can contain uncontrolled cargo materials, hence the provision of fire extinguishers in these areas. The fire retardant treatment of the insulation blankets serves as a backup to prevent any spread of fire and the automatic equipment cooling override serves to expel any smoke overboard by opening the outflow valve (this works in flight when differential pressure exists). It would be very difficult to design a fire extinguishing system for the MEC that would not compromise any of the avionics (for example, foam might damage electronic circuit boards). Therefore, at this time there does not appear to be sufficient justification to require fire extinguishing equipment to be installed in the MEC.

A solution for reducing the risk of fire in the MEC from failed contactors is to install a containment tray beneath the open power panels. The aircraft manufacturer and power panel manufacturer developed a containment tray modification (see Figure 49 and 50, page 72) which connects to the base of the P100, P200 and P300 panels and will catch molten metal droplets from an uncontained contactor failure. Thermal modelling revealed that the tray would contain a 1,000°C molten copper droplet (10 x 10 x 2 mm) without melting the tray. Had this type of tray been installed on the P200 panel on N786UA it is probable that the RGCB and RBTB contactor failures would have been contained and no insulation blanket fire would have occurred. The containment tray modification became available for retrofit on 20 July 2007 when Service Bulletin 777-24-0106 was published. The recommended compliance time in the Service Bulletin was 60 months. In July 2007 the AAIB informally recommended to the FAA that the containment tray Service Bulletin should be made mandatory via an AD and that the compliance time should be reduced to 24 months. The FAA agreed and eventually negotiated with the aircraft manufacturer a reduction in compliance period to 36 months. However, the proposed AD was not presented to the FAA AD board until May 2008. At the time of writing an NPRM (Notice for Proposed Rule Making) for the AD was being prepared by the FAA for open consultation. The AAIB considers the time elapsed from the issuance of the Service Bulletin in July 2007 to the as-yet unpublished AD to be unacceptable and therefore recommends that:

The Federal Aviation Administration, in conjunction with the European Aviation Safety Agency should mandate that all Boeing 777 aircraft be equipped, at the earliest opportunity, with a containment tray below the open base of the P100, P200 and P300 power panels, to prevent any hot debris from a failed contactor from falling on to insulation blankets or other components and causing heat and fire damage. (**Safety Recommendation 2009-025**)

2.6 Action to prevent future recurrence

The N786UA contactor failure event and all other known contactor failure events have occurred on the ground. It appears that contactor failures are more likely to occur on the ground than in the air because they follow on from a switching event. Contactors are unlikely to change state in the air unless a failure occurs such as an engine failure or IDG failure, so the probability of an in-flight contactor failure can be calculated to be very low. However, the investigation has revealed the presence of debris inside some contactors and conductive debris can create a short-circuit. It would be possible for debris to migrate into a short-circuit position as a result of in-flight turbulence. This could trigger a contactor breakdown without requiring a switching event. There is insufficient data to calculate the probability of this occurring, but it is a risk that should be borne in mind by the authorities evaluating the safety recommendations in this report.

The containment tray modification (Safety Recommendation (2009-025)) will reduce the risk of fire following an uncontained contactor failure on the ground or in the air. However, it does not address the root cause of failure and it does not guarantee containment, as larger molten droplets than that assumed in the thermal modelling could still pass through the containment tray. Therefore it is important that the recommended contactor retrofit is also mandated (Safety Recommendation 2009-022). The newly modified contactors address a number of the failings uncovered during the investigation. They do not necessarily fix the unknown root cause of the N786UA contactor failure, but the larger arc chute, improved heat resistant materials and additional internal insulation reduce the risk of a repeat failure from resulting in an uncontained contactor failure.

The power panel cooling modification may also reduce the risk of a recurrence of the N786UA failure event, but analysis of the possible contactor failure causes revealed that excessive heat was not necessarily the initiating cause of failure. Therefore it is accepted that although beneficial, the cooling

modification need not be made mandatory. However, Boeing 777 operators operating in hot regions of the world are advised to carry out the cooling modification as recommended in the Service Bulletin.

3 Conclusions

3.1 Findings

1. The aircraft was serviceable and there were no indications of any problems until the right Integrated Drive Generator (IDG) came online after engine start.
2. Within five seconds of the 'No Break Power Transfer', the Bus Power Control Unit (BPCU) detected a fault with the Right Generator Circuit Breaker (RGCB), a Right Main Bus under-voltage was detected, and an unusual 'growling' noise was heard by the flight crew which emanated from the region near the P200 power panel.
3. An 'ELEC AC BUS R' failure caution message appeared on the Engine Indication and Crew Alerting System (EICAS) and the flight crew carried out the checklist items for this message.
4. The RGCB and Right Bus Tie Breaker (RBTB) suffered from severe internal arcing and short circuits which generated temperatures in excess of 1,000°C, and resulted in uncontained failures. The RGCB was probably the first to fail.
5. Molten copper and silver droplets from the failed contactors dropped down through the open base of the P200 panel and ignited the insulation blankets below.
6. The insulation blanket fire spread underneath a floor panel to the opposite P205 power panel, causing heat and fire damage to structure, cooling ducts and wiring.
7. The Main Equipment Centre (MEC) smoke detector was triggered 42 seconds after the electrical failure event.
8. The detection of smoke in the MEC triggered the 'Equipment Cooling Override' mode and displayed a 'EQUIP COOLING OVRD' advisory message to the flight crew but no 'smoke' message.
9. The flight crew first became aware of the smoke four and a half minutes after the failure event, when the tug driver noticed smoke emanating from one of the MEC vents and notified the flight crew via the interphone.

10. The flight crew decided to shut down the right engine and taxi to a nearby stand in order to evacuate the passengers using the steps.
11. The Airfield Fire Service attended the aircraft when it arrived on stand, entered the MEC and discovered significant smoke but no fire.
12. The insulation blankets had self-extinguished and tests revealed that the insulation had similar flame retardant properties to new insulation of the same type.
13. The RGCB and RBTB contactors had suffered such severe internal damage that it was not possible to determine the initiating point of failure or the root cause of failure.
14. A number of possible causes of contactor failure were considered, but there was insufficient evidence to select a most probable cause of failure.
15. The most likely causes of contactor failure included a debris induced short-circuit, a debris induced fouling of the armature, a loss of over-travel due to heat build-up, erosion and/or assembly errors, and arc tracking across the unprotected region of the stationary contact support block.
16. A number of modifications to the contactor design have been carried out that should make the contactor more resistant to failure and more resistant to an uncontained failure.
17. The electrical protection system was not designed to detect and rapidly remove power from a contactor suffering from severe internal arcing and short-circuits.
18. Since the accident a containment tray modification to the power panel has been developed which could have prevented the molten metal droplets from igniting the insulation blankets.

3.2 Causal factors

The following causal factors were identified:

1. An internal failure of the Right Generator Circuit Breaker or Right Bus Tie Breaker contactor on the P200 power panel inside the Main Equipment Centre resulted in severe internal arcing and short-circuits which melted the contactor casings. The root cause of contactor failure could not be determined.
2. The open base of the P200 power panel allowed molten metal droplets from the failed contactors to drop down onto the insulation blankets and ignite them.
3. The aircraft's electrical protection system was not designed to detect and rapidly remove power from a contactor suffering from severe internal arcing and short-circuits.
4. The contactors had internal design features that probably contributed to the uncontained failures.

4 Safety Recommendations

The following Safety Recommendations have been made:

- 4.1 **Safety Recommendation 2009-021:** Boeing Commercial Airplanes should consider implementing differential current fault protection of main power contactors when designing future electrical systems.
- 4.2 **Safety Recommendation 2009-022:** The Federal Aviation Administration, in conjunction with the European Aviation Safety Agency, should consider mandating the replacement of ELM 827-1 contactors with ELM 827-3 contactors on all Boeing 777 aircraft, to reduce the risk of a contactor breakdown that results in uncontained hot debris.
- 4.3 **Safety Recommendation 2009-023:** Tyco Electronics Corporation should introduce mitigating action to reduce the risk of auxiliary contact blade failure in ELM 827 and ELM 828 contactors, in order to prevent a broken blade from causing a short-circuit failure.
- 4.4 **Safety Recommendation 2009-024:** The Federal Aviation Administration, in conjunction with the European Aviation Safety Agency, should mandate that all Boeing 777 aircraft be equipped, at the earliest opportunity, with a software update that will generate a caution message to alert flight crew of the presence of smoke in the Main Equipment Centre.

The aircraft manufacturer responded to this Safety Recommendation by stating:

‘Boeing is undertaking a review of system architecture, smoke detection, flight deck indications, and flight crew procedures across all of our production models to ensure a consistent approach to fireworthiness and flight crew indication, and identify safety enhancements that may be warranted. This work will include a review of the “SMOKE EQUIP COOLING” message for 777 passenger aircraft.’

- 4.5 **Safety Recommendation 2009-025:** The Federal Aviation Administration, in conjunction with the European Aviation Safety Agency, should mandate that all Boeing 777 aircraft be equipped, at the earliest opportunity, with a containment tray below the open base of the P100, P200 and P300 power

panels, to prevent any hot debris from a failed contactor from falling on to insulation blankets or other components and causing heat and fire damage.

K Conradi
Principal Inspector of Air Accidents
Air Accidents Investigation Branch
Department for Transport
March 2009

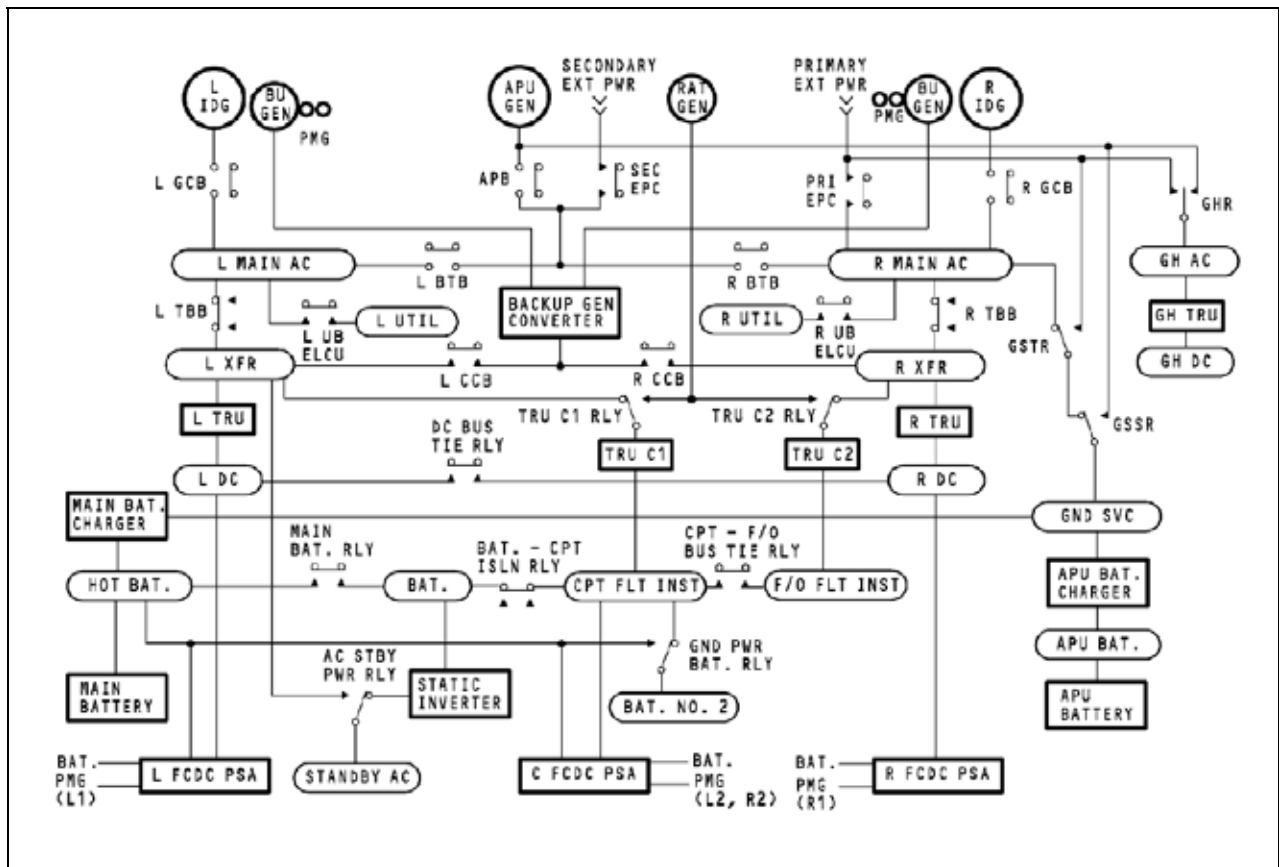

Abbreviations and Acronyms

- AFDC - automatic flight director computer
- AFDS - automatic flight director system
- APB - auxiliary power breaker
- AUTO - automatic
- AVAIL - available
- BAT - battery
- BPCU - bus power control unit
- BTB - bus tie breaker
- BU - backup
- CCB - converter circuit breaker
- CONV - converter
- CPT - captain
- CPU - central processing unit
- CSD - constant speed drive
- CTRL - control
- DISC - disconnect
- EDIU - engine data interface unit
- EEC - electronic engine control
- EEU - ELMS electronic unit
- ELCU - electrical load control unit
- ELMS - electrical load management system
- EMI - electro-magnetic interference
- EP - external power
- EPC - external power contactor
- ESDS - electro-static discharge sensitive
- ETOPS - extended twin operations
- FBW - fly by wire
- FCDC - flight controls dc
- FLT - flight
- FNC - fiber nickel cadmium
- F/O - first officer
- GCB - generator circuit breaker
- GCR - generator control relay
- GCU - generator control unit
- GEN - generator
- GH - ground handling
- GHR - ground handling relay
- GND - ground
- GSSR - ground service select relay
- GSTR - ground service transfer relay
- HDLG - handling
- IDG - integrated drive generator
- ILS - instrument landing system
- INST - instrument
- I/O - input/output
- ISLN - isolation
- LRM - line replaceable module
- LRU - line replaceable unit
- PEPC - primary external power contactor
- PFC - primary flight computer
- PMG - permanent magnet generator
- POR - point of regulation
- PRI - primary
- PSA - power supply assembly
- PSU - power supply unit
- PWR - power
- QAD - quick attach/detach
- RAT - ram air turbine
- RLY - relay
- SCM - signal conditioning module
- SEC - secondary
- SEPC - secondary external power contactor
- STBY - standby
- SVC - service
- TBB - transfer bus breaker
- TRU - transformer rectifier unit
- UB - utility bus
- UTIL - utility
- XFR - transfer

Figure A-1

Boeing 777 Electrical Power System Schematic

Appendix B

The timeline in Figure B-1 below shows the time intervals between the GCB being commanded to close and the BTB being commanded to trip during an NBPT. The minimum time required for the GCB to close after being commanded to close was 6 ms. The maximum time required for the BTB to trip after being commanded to trip was 20 ms. Therefore, in accordance with the figure below, the maximum possible duration of parallel sources was 24 ms.

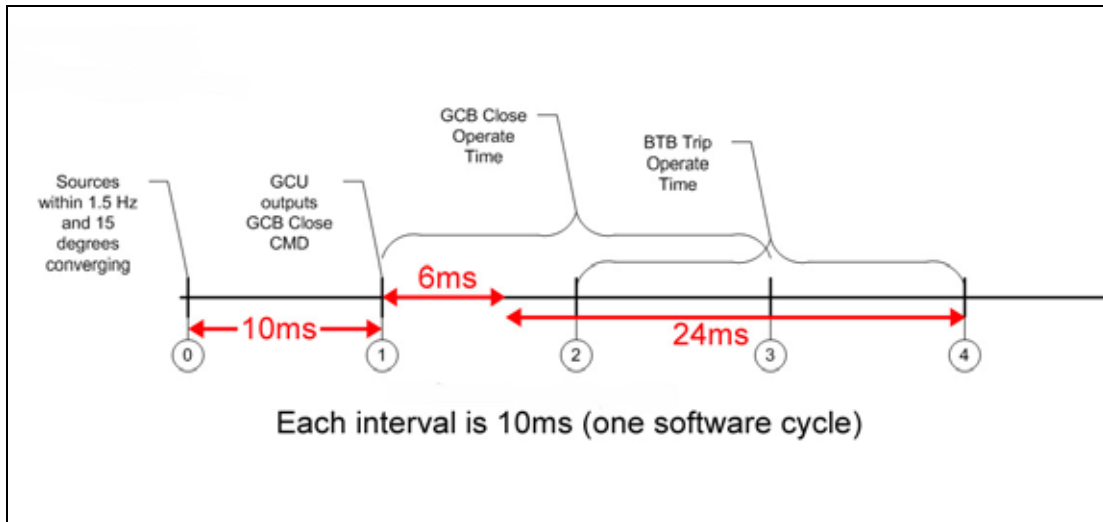

Figure B-1
NBPT timeline diagram

Analysis of NVM fault messages

The RGPU and BPCU contained several fault messages for the period of the failure event. These are presented below with an explanation of the meaning of each message and an analysis of what might have caused the message (the times listed are the times that the message was generated, which in some cases was a few seconds after the fault was first detected).

1000:46 BPCU: RGCB CLOSE AUX DISAGREE

This message means that the RGCB has been commanded to close and the RGCB auxiliary contact to the RGPU indicates closed, but the auxiliary contact to the BPCU indicates open (condition required for 1.5 ± 0.5 seconds). The RGCB has four auxiliary contacts that transmit its contact state to the three GCUs and BPCU. Since the RGPU, LGPU and AGCU had not triggered failure messages, this indicated that the RGCB had probably closed correctly and that there was a fault with the auxiliary contact that was wired to the BPCU. The examination of the RGCB revealed that the auxiliary contact blades were intact, so a severed or disconnected wire from the auxiliary contact to the BPCU was the most likely explanation of the failure message. This wire was probably damaged as a result of internal arcing or short circuits.

There was no accompanying message about a failure of the RBTB to open following RGCB closure, so the RBTB probably opened and completed a successful NBPT.

1000:57 BPCU: RIGHT MAIN BUS PHASE C OPEN WIRE

This message means that the BPCU has detected that the main bus phase C voltage has been less than 20V for 10.5 ± 0.5 seconds. The right main bus phase C voltage is measured inside the PEPC at the C phase. The PEPC and its sense line were undamaged, so the under-voltage detection was probably correct and would have occurred as a result of an open circuit within the C phase power source, potentially caused by a short circuit event.

1000:57 RGPU: RGPU MAIN BUS PHASE C FAULT

This message means that the contactors are closed in such a configuration that the right main bus should be powered, but the RGPU has detected that the main bus phase C voltage has been less than 20V for 10.5 ± 0.5 seconds.

Appendix C

The RGCU also senses right main bus voltage inside the PEPC and this message was concurrent with the under-voltage detection from the BPCU which was further evidence that a genuine under-voltage of the bus had occurred.

1001:02 RGCU: RGCB CLOSE FAULT

This message means that the RGCB auxiliary contact to the RGCU indicates open even though the last command was for the RGCB to close (condition required for 0.15 seconds). The last command from the RGCU to the RGCB was a 'close' command when the IDG came online. This command had not changed, so this message was triggered as a result of the auxiliary contact to the RGCU suddenly indicating open. This was probably caused by the sense line becoming severed as a result of internal arcing.

1001:04 RGCU: RIGHT FEEDER DIFFERENTIAL PROTECTION

This message means that the RGCU has detected a difference in current between the generator Current Transformer (CT) inside the IDG and the CT at the feeder connection of the P200 panel (near the RGCB) of 40 ± 7.5 Amps for 0.06 ± 0.02 seconds. This message will cause the RGCB to be commanded to trip. The reason for the 'Differential Protection' activation was not clear. It is designed to detect and protect against shorts within the feeder cables between the IDG and the P200 panel, but no such short-circuits occurred. The cables and their connections to the panel had not been compromised. One explanation is that the internal arcing of the RGCB and RBTB induced faults within the Current Transformers (CT) that were used to detect a short-circuit within the feeder cables. False CT readings then caused 'Differential Protection' to be activated, so this protection was activated in error, rather than by design.

1001:04 RGCU: RGCB TRIP FAULT

This message means that the RGCB was commanded to trip, but the RGCB auxiliary contact to the RGCU indicates closed (condition required for 0.07 seconds). The RGCB was commanded to trip as a result of 'Differential Protection', but a failure of the auxiliary contact sense line caused the RGCU to sense that the RGCB had not tripped.

1001:07 RGCU: RBTB TRIP FAULT

This message means that the RBTB was commanded to trip, but the RBTB auxiliary contact to the RGCU indicates closed (condition required for 0.07 seconds). This is the first indication of a problem with the RBTB. It is not clear why the RBTB has been commanded to trip, but the failure message indicates a problem with the auxiliary contact sense line so this probably indicates that internal arcing has progressed to the RBTB.

1001:15 RGCU: RGCU TIE BUS PHASE C OPEN WIRE

This message means that the RGCU has detected that the Tie Bus phase C voltage has been less than 20V for 10.5 ± 0.5 seconds, when the Tie Bus was expected to be powered based on the system configuration. The Tie Bus voltage is measured inside the RBTB. The APU generator was still powering the Tie Bus at this point and no other unit reported a loss of Tie Bus voltage, so this message was probably a result of a failure of the voltage sense line inside the RBTB. This was probably caused by further degradation as a result of internal arcing.

1001:17 BPCU: GSTR DISAGREE

This message can mean different things but relates to the GSTR (Ground Service Transfer Relay, also known as the GSR, Ground Service Relay) auxiliary contact state and relay driver command (condition required for 5.5 seconds). The GSTR is mounted directly below the RBTB so this failure message is probably a result of collateral damage.

1001:43 RGCU: 28 VOLT SWITCH POWER FAULT

This message means that the RGCU has detected an over-current on the 28V line which powers the contactor coils in the RBTB and RGCB (condition required for 1 second). This is a common fault of the GCB-BTB drivers and was most likely an induced fault as a result of the RBTB and RGCB contactor breakdowns.

Timeline of relevant events from CVR, FDR and NVM data

The timeline below is not comprehensive and only includes relevant information. The text in square brackets pertains to information from the FDR or GCU NVM. The text in normal brackets relate to comments. All other text relates to information obtained from the CVR.

- 1000:35 [Right engine N2 reaches 51.4%] – (RGCB will be commanded to close 6±1 sec after right engine reaches 51% N2)
- 1000:37 [Right and Left IDG indicate 115V output]
- 1000:39 [Left engine N2 reaches 50.7%]
- 1000:44 [BPCU detects an RGCB close aux disagree fault]¹
- 1000:46 [BPCU and RGPU detect a right main bus under-voltage]²
Start of unusual noise on CVR (this was an intermittent noise which the flight crew described as a low pitch ‘growling’ noise, but is recorded by the area microphone as a more high-pitched noise comprised of many different frequencies³)
- 1000:48 FO⁴ says “Two good starts”
- 1000:49 FO says “Something happened”
Sound of four warning tones at 0.25 second intervals (consistent with the master caution tone for ‘ELEC AC BUS R’ failure)
- 1000:51 FO says “I just saw my... my panel went bonkers” (referring to the fact that his Primary Flight Display and Navigation Display had momentarily blanked)
- 1001:02 [RGPU detects RGCB as open but last command was for it to close]
- 1001:04 [RGPU Differential Feeder Protection trips right generator exciter field and sends trip command to RGCB]
[RGPU RGCB trip fault, last command was for it to trip but detected as closed]
[RGPU detects Tie Bus under-voltage]
- 1001:06 FO says “right AC bus unpowered”

1 This time ‘1000:44’ is taken in this report to be the time of the failure event.

2 This is the time that the under-voltage is first detected. The actual error message was generated 10.5 seconds later, once the under-voltage condition had lasted for at least 10.5 seconds. All NVM messages are listed in this summary with their detection time rather than their ‘message generated’ time.

3 The area microphone records frequencies between 150 Hz and 6 KHz. A low ‘growling’ noise could be in the region of 30 to 40 Hz.

4 FO refers to First Officer.

Appendix D

- 1001:07 [RGCU RBTB trip fault, last command was for it to trip but detected as closed]
- 1001:08 Jump-seat FO says “You hear it? It’s still going crazy. I’d give it a second here and let it...” (this is a reference to the multiple EICAS messages and overhead lights)
- 1001:11 [BPCU detects a GSTR disagree]
- 1001:12 FO says “Listen to it. It’s going nuts” (this is also referring to the EICAS display with multiple messages)
- 1001:22 FO asks captain “You want the electrics displayed boss...”
- 1001:26 Sound of cooling fans powering down⁵
- 1001:27 [EE Bay Smoke Warn discrete is triggered on FDR]
FO says “Oh, that is not a good sign. The whole right main bus just crashed” (FO stated in interview that this reference was probably in relation to the ‘powering down’ sound and not any new EICAS message)
- 1001:32 “Let’s go back to the checklist”
- 1001:42 “Right generator control switch”, “Off and on, attempt only one reset”
[Last NVM fault message: RGCU 28V switch power short]
- 1001:46 “Off...”
- 1001:49 “... and on” (the FO stated in the interview that the Right Gen Control switch remained illuminated ‘off’ after it was cycled off and on)
- 1002:12 FO says “APU, it is on”
- 1003:10 An RT call is made to Operations to report a maintenance issue
- 1003:16 [Master Warning discrete on FDR but no warning tone heard on CVR]
- 1003:25 An RT call is made to Ground control about a mechanical problem and that they will probably need to go back to the gate
- 1003:42 Sound of unusual noise on CVR (last time that it is heard on CVR)
- 1003:44 FO says “It’s just making the weirdest noises I’ve ever heard”
- 1003:57 (sounds of sniffing) “That smells”, “Ooh that’s not good” (the captain stated in interview that it was an electrical burning smell; the FO said he had smelt similar smells from the galley before)
- 1004:08 FO “This is the problem. This has gone into override mode too” (FO stated in interview that at this point he first noticed the equipment cooling override light on the overhead panel; the captain stated that he had noticed it earlier)

⁵ The sound of cooling fans powering down is in response to ‘Equipment Cooling Override’ activation which is in response to the smoke detection. Therefore, 1001:26 is the time of smoke detection.

Appendix D

- 1004:15 Discussion between flight crew about shutting down the right engine
- 1004:23 [right engine fuel cutoff and right engine starts to spool down]
- 1004:42 [Master Warning discrete on FDR but no warning tone heard on CVR]
- 1004:47 Flight deck door is opened. FO and jump-seat FO advise cabin crew of a problem with the equipment cooling and the electrics but that there was no fire
- 1005:14 Tug driver advises on interphone “There’s a lot of smoke coming out of the vents” (when the tug driver saw smoke he left his vehicle and plugged his headset into the aircraft’s interphone at the nose of the aircraft to inform the flight crew)
- 1007:25 Ground control advises on RT that there’s a large amount of smoke coming from one of their engines and advises that a ‘local standby’ will be placed on the aircraft
- 1008:55 [aircraft starts to taxi based on FDR groundspeed]
- 1010:35 [aircraft stops taxiing based on FDR groundspeed]
- 1010:51 [left engine fuel cutoff and left engine starts to spool down]
- 1011:13 Ground control advises on RT that it has been upgraded to an ‘aircraft ground incident’ after smoke was seen coming from their avionics bay
- 1013:00 PA announcement to passengers for them to disembark
- 1014:23 Discussion about depowering the aircraft (in interview crew stated that they shut down the APU at this point but left the battery on)
- 1014:30 Sound of cockpit window opening
- 1014:41 End of CVR recording

Vertical Bunsen Burner Results:

PART NUMBER	SAMPLE	SURFACE	BURN LENGTH	EXTING TIME	DRIP EXTING TIME
415W0110-312 (Upper Half)	C1A	Inboard	5.4	0	0
	C1B	Inboard	4.3	0	ND
	C1C	Inboard	4.3	0	ND
	C1B	Outboard	5.1	0	ND
	C1C	Outboard	3.8	0	0
415W0110-312 (Lower Half)	C3A	Inboard	4.6	0	ND
	C3B	Inboard	1.0	0	ND
	C3C	Inboard	1.0	0	ND
415W0110-314	C2A	Film: Selvage	1.5	0	ND
	C2B	Film: Selvage	3.0	0	ND
	C2C	Film: Selvage	2.5	0	ND
	C2D	Inboard	3.0	6	ND
C2E	Inboard	4.3	0	0	
415W0110-459	D1A	Outboard	3.6	0	0
	D1B	Outboard	0.5	0	0
	D1C	Outboard	1.0	0	0
Requirement; FAR 25.853			8.0	15	5

ND = No Drip

Table E-1

Results from the vertical Bunsen burner flammability test (note: burn length is in inches and time is in seconds)

Appendix E

Modified Cotton Swab Test Results:

PART NUMBER	SAMPLE (1) (2)	SURFACE	APPROX. BURN LENGTH (IN) (2) (3)	APPROX. BURN AREA (IN ²) (5)
415W0110-312 (Upper Half)	C1 - Flat	Inboard	1.0	3
	C1 - Edge	Inboard	1.0	3
	C1 - Crease	Inboard	Vertical - 8.0 (4)	36
	C1 - Crease	Outboard	Vertical - 8.0 (4)	58
415W0110-312 (Lower Half)	C3 - Flat	Inboard	1.0	3
	C3 - Crease	Inboard	Vertical - 9.0 (4)	65
	C3 - Crease	Outboard	Vertical - 9.0 (4) Horizontal - 7.0	90
415W0110-314	C2 - Flat	Inboard	1.0	3
	C2 - Flat	Outboard	1.0	3
	C2 - Crease	Inboard	Vertical - 6.5	20
	C2 - Crease	Outboard	Vertical - 7.0 (4) Horizontal - 6.5	70
415W0110-459	D1 - Crease	Outboard	Vertical - 9.5 (4)	55
FAA Handbook Requirement (7)	24" x 40"		8.0	Not Applicable (6)

NOTES:

- (1) Cotton swab testing does not demonstrate the elevated heat exposure or the type of ignition source present during the UAL 777 fire event.
- (2) Sample configurations did not conform to BSS7357 requirements and were non-standard due to available size limitations, cutouts, and design configurations using tape and thread.
- (3) The effect of in-service environmental exposure and contamination on the material performance is unknown.
- (4) Stitching thread, taped edges, and other blanket design details contributed to burn length.
- (5) No requirement for burn area. Data provided as reference only.
- (6) A 16" diameter circle equals 200in².
- (7) FAA Fire Test Handbook, Chapter 22, http://www.fire.tc.faa.gov/pdf/handbook/00-12_ch22.pdf

Table E-2

Results from the Cotton swab flame propagation test

Tyco report on endurance contactor test



Tyco Electronics
Global Aerospace & Defense
HARTMAN
175 N. Diamond St.
Mansfield, Ohio 44902
Telephone: 419-521-9500
Facsimile: 419-526-2749
www.tycoelectronics.com

October 26, 2007

TEST REPORT

P200 ENDURANCE LOAD TEST OF BP-493-1 CONTACTOR MOUNTED TO P200 PANEL

Document prepared by: Richard Gorenflo, Product Development Engineer, Tyco Electronics

Ref Documents:

ST-P200-01

FP-1373

Purpose:

The contactor was tested in a simulated aircraft environment to determine if the contactor would be damaged under typical high level current loads and to establish a baseline for contact wear for various contactor cycle counts.

Testing:

The test was conducted under the parameters of special testing document ST-P200-01.

The contactor was subjected to testing in accordance with Functional Test Procedure FP-1373 at the beginning of the test and at 25,000 and 50,000 cycles of operation.

The contactor was subjected to thermal excursions by running 45 minutes of continuous current before each set of 5000 cycling operations.

Temperatures of the contactor and panel bussing at selected locations were monitored by thermocouple and were recorded at the conclusion of the 45 minutes of continuous current and at each 1000 cycles of operation. The temperature charts are included as Appendix 1.

At the conclusion of each 5,000 cycles of operation the contactor was removed from test and photographs were taken of the P200 panel backplane and the contactor. The exterior of the contactor was photographed and then the cover was removed for inspection and internal photos of the assembly and the contacts. The contactor was also checked for operating voltage at each of these examinations. Photographs are available as separate files.

Main contact over-travel (or wear allowance) was measured after the contactor's initial adjustment and at each 5,000 cycle examination.

Oscilloscope traces of contact opening and closing were taken as samples during each 5,000 cycle run. Representative scope print-outs are included as Appendix 2.

Test results:

The test sample was pulled from current production and was identified as RBTB Unit 1. The configuration differences between the test contactor and the contactors from ELMS 1 production in 1995 are enumerated in Appendix 3. Adjustment of the contactor settings to manufacturing parameters was done by the Product Engineer in charge of the testing.

The test panel was mounted in the environmental chamber and the chamber was set for altitude and ambient as described in the test plan. The test set-up is shown in photos in the "SET UP" folder. The position on the panel for the test contactor was the Right Bus Tie Breaker position. The 400 Hz generator was connected through feeder cables representative of the aircraft cable to the P200 panel terminals to parallel input lugs L7, L27 (phase A), L8, L28, (phase B), and L9, L29 (phase C) feeding the RBTB. The current passed through the P200 bussing to the neighboring Right Generator Control Breaker (also a BP493-1 contactor) and was tied to the loads through paralleled panel terminals L1, L4 (phase A), L2, L5 (phase B) and L3, L6 (phase C) from the RGCB. The GCB was closed and powered throughout the test and was monitored for internal temperature in 2 locations, but was not considered a test subject of the cycling test.

Before the start of each 5,000 cycle set, the contactor was set to the closed position and load current was applied continuously for 45 minutes. The temperature of the contactor plungers and the panel busses was recorded at the end of the 45 minutes. Contactor cycling was then started at 2 seconds per cycle and a 25% duty cycle. While cycling the contactor internal temperatures went down as shown on the Appendix 1 charts.

The contactor was monitored through a miss detector which compares the coil voltage signal to the contact state (open or closed) and shuts the test off if there is a disagreement of contactor status vs. command. No misses were detected during the 50,000 cycle duration of the test. The periodic measurement of contact arcing showed that the arc extinguished within a half cycle of the 400 Hz current. This arcing result was sustained throughout the test with no sample showing arcing in excess of a half cycle.

At 5,000 cycles of operation the contactor was functioning properly and exhibited light discoloration of the contactor cover plate and backplane from temperatures achieved during the continuous current portion of the testing. The contact photos in folder 5K show that the contact burn patterns are somewhat off from the contact centers with phase A burn pattern extending to the contact edge. See Table 1 for measurement of remaining contact over-travel.

At 10,000 cycles of operation the contactor was functioning properly and some additional discoloration from heat was evident. The contact burn pattern was slightly larger. The oscilloscope monitoring contactor cycling was showing an occasional double contact break on trip command. This was attributed to the setting of the throat cut switch for the trip coil. The condition was monitored and the decision was made to continue the test with that condition for a time. See photos in folder 10K.

At 15,000 cycles of operation the contactor was functioning properly. Heat from continuous current operation was starting to discolor the epoxy holding thermocouples to the plungers. There was, however, no contactor damage due to heating effects. At this point, the contacts are worn similarly to those on the 8 to 10 year old contactors from the High Time/ High Cycle field study. Soot from contact blow-off was beginning to be evident inside the arc chute. The amount of material worn away was minimal. See Table 1. Internal temperatures of the contactor plungers were holding steady and, in some cases, reducing indicating that voltage drop was probably getting better as the contacts wore in. The intermittent throat cut switch problem continued.

At 20,000 operations the slow progression of wear is evident by the photos. See folder 25K.

At 25,000 cycles contact burn patterns had migrated to the edges of the contacts and involve most of the contact surface. The amount of soot from arc blow-off is building on the inner surfaces of the arc chute. A light amount of contact debris (dust) had settled to the inside of the cover on the bottom relative to the installation orientation. At this check a small ball (approx. .015 Dia.) of silver colored material was found in the cover. This was later found to be a solder ball. The origin was probably the wire soldering to the pc boards during manufacturing. The ball had a flat spot where it had fallen against a part in the contactor and had probably adhered. The particle was too small to be a short circuit threat.

The contactor passed all requirements of the FTP. However, the sporadic throat cut switch problem on trip was still detected. The voltage drop on all three phases was slightly higher than the condition at 0 cycles. See Table 2. The wear away of contact material had practically halted with material now being distributed and re-distributed on the contact surfaces. See Table 1. The photos (folder 25K\Mov Cont B) show a shiny area at the center of the B phase contact set. This appears to be an area of significant contact melt and possible material transfer. Microscopic examination showed that the spot was probably involved in melting during contact make, but little material transfer was occurring indicating no welding.

At this examination the throat cut switch was adjusted properly and no further occurrence of the double break on trip showed for the remainder of the test.

The contactor was returned to cycling test with the environmental conditions changed to room ambient temperature and pressure in accordance with the test plan.

At 30,000 cycles the contactor condition was very similar to the condition at 25,000 cycles. At this inspection it was noted that the push rod head on Phase C was collecting filings magnetically attracted to the push rod. These are particles from mechanical wear from push rods rubbing on the movable contact supports. The particles are dust size and pose no electrical or mechanical risk for the contactor. The progression of discoloration from heating has halted because operating temperatures without the 60 degree C ambient environment are lower than those achieved during the pervious portion of the test.

At the 35,000 and 40,000 cycle checks the contactor condition was showing slowly progressing additional wear. Contact material re-distribution on the contact surfaces was causing the contact over-travel measurement to vary within the range of approximately .001 inch from one check to another. The contacts continued to look about the same as the previous 10,000 cycles. The C phase contact was beginning to show some darkening of color from staining by the contact blow-off and some out-gassing of the plastic arc chute material which is getting hit with arc plasma on each cycle. The contactor continued to operate properly with internal temperatures holding steady or decreasing slightly.

At the 45,000 cycle check the contactor was functioning properly and remaining contact over-travel was holding steady. Contactor and panel temperatures were still holding steady as well. At this examination a piece of brass shim material was found inside the contactor cover. The piece is approximately .300 X .150 X .005 and is a piece of a shim that is used in the armature gap to reduce magnetic force. There are two of these shims placed side by side. The second one was still in place and the armature magnetic properties were unaffected by this piece breaking off. (See photo in folder 45K\7 armature shim) The breaking of the shim is attributed to fatigue from mechanical flexing of the part. If the forming of the shim is not very close to 90 degrees, the shim will flex each time it hits the motor pole face.

The B phase contact mating point has migrated to near the front edge of the contact causing material splatter to create a ragged edge on the contact. The temperatures on the B phase conductors are holding steady indicating that contact is still not deteriorating.

The loose shim piece was removed and the contactor was returned to test.

At the conclusion of 50,000 cycles the contactor was removed from testing and subjected to the full FTP. The contactor failed the new product specification for voltage drop on the B phase testing 187.6 mV average against a specification of 175 mV max. The contactor passed all other requirements of the functional test procedure. Of special interest here is the Dielectric Withstand Voltage test which is an indicator of the effects of contamination and debris from contact arc blow-off. The unit passed this test indicating that no phase to phase or phase to ground conductive paths or arc tracks were created by the normal contact arcing action.

The unit was opened for internal examination. The contacts were all beginning to be stained from soot from arcing and arc chute out-gassing. The B phase contact set was showing material movement around the front edge. This rough condition is the probable cause of the increase in voltage drop on the B phase. The contact over-travel measurement remained unchanged from the values recorded at the 25,000 cycle mark. B phase conductor temperatures have risen slightly over the last 20,000 cycles in correlation to the voltage drop increase.

The unit was then mounted to the P200 panel without the cover, using screws, washers and spacers to simulate normal installation. The contactor was then cycled under 350 ampere load at 115VAC to visually record the arcing. The "Movie" file contains a video of the arc flashing occurring in the contactor. Note that the magnitude of the arc flash varies from cycle to cycle from not visible to bright. This variation results from the point along the sine wave where contact break occurs. A break near zero crossing results in very little arcing.

This test unit will be scheduled for fault testing.

Remaining Wear Allowance, inches			
cycles	A	B	C
Start	0.023	0.022	0.022
5000	0.021	0.020	0.020
10000	0.021	0.020	0.020
15000	0.020	0.019	0.019
20000	0.021	0.019	0.019
25000	0.021	0.019	0.019
30000	0.021	0.019	0.019
35000	0.021	0.019	0.019
40000	0.020	0.018	0.019
45000	0.020	0.019	0.019
50000	0.021	0.019	0.019
Delta			
Start/end	-0.002	-0.003	-0.003
max	-0.003	-0.003	-0.003

MV	A	B	C
Start	115	138	123
25,000	136.8	162.6	126.8
50,000	141.4	187.6	158.7

Conclusions:

The continuous current testing for 45 minutes at approximately 350 Amps represents a case more applicable to the APB contactor in the P300 panel than the RBTB in the P200 panel. The normal continuous loading on the RBTB is less than 120 KVA. There are no field cases known where the discoloration from heating effects as shown in this test was present on a Bus Tie Breaker. The heating effects on this contactor do, however, serve to simulate aging of the contactor.

The contactor performed as expected and contact wear results indicate serviceable contact life well beyond the amount of wear seen on High Time/High Cycle contactors returned from the field. Temperatures remained below thresholds where damage to materials would occur. The contactor voltage drop appeared to vary over the cycling life test as indicated by up and down variations in the conductor temperatures. This is from the changes in contact seating as the contacts wore. The voltage drop had a gradual upward trend over the 50,000 cycles as expected. The A phase circuit voltage drop increased 23% from the new unit values, the B phase drop increased 36% and the C phase drop increased by 29%. The highest voltage drop measured at the completion of 50,000 operations was 12.6 mV above the new product specification limit.